

## Instruction and Operation Manual

# S230/S231 S230 Ex/S231 Ex

## Dew Point Transmitter for Ex Applications



The Dew Point Transmitter with optional hazardous approval for applications in demanding industrial applications and hazardous environments.

Dear Customer,

Thank you for choosing our product.

The operating instructions must be observed before you start up the device. The manufacturer cannot be held liable for any damage which occurs as a result of non-observance or non-compliance with this manual.

Should the device be tampered with in any manner other than a procedure which is described and specified in the manual, the warranty is cancelled and the manufacturer is exempt from liability.

The device is destined exclusively for the described application.

SUTO offers no guarantee for the suitability for any other purpose. SUTO is also not liable for consequential damage resulting from the delivery, capability or use of this device.

## Table of contents

1	Safety Instructions.....	5
2	Registered Trademarks.....	7
3	RF Exposure Information and Statement.....	8
4	Application.....	9
5	Features.....	9
6	Technical Data.....	10
6.1	General.....	10
6.2	Electrical Data.....	11
6.3	Output Signals.....	11
6.4	Accuracy .....	11
7	Dimensional Drawing.....	13
8	Installation.....	14
8.1	General Installation Considerations.....	14
8.2	Medium Temperature .....	14
8.3	Cable Entries.....	14
8.4	Fuse.....	14
8.5	Determination of the Installation Point.....	14
8.6	Installation Requirements.....	15
8.7	Installation to Compressed Air / Gas .....	15
8.8	Electrical Connection .....	17
9	Ex Version S230 Ex/S231 Ex.....	17
9.1	Special Conditions for the Ex Version.....	17
9.2	Examination Certificates, Certificate of Conformity.....	18
9.3	Intrinsic Safety Ratings and Parameters.....	18
9.4	Name Plates.....	18
9.5	Installation.....	20
9.5.1	General Installation Considerations.....	20
9.5.2	Cable Entries.....	20
9.6	Potential Equalization.....	20
9.7	Service Kit.....	21
9.8	Back Cover / Security Seal.....	21
9.9	Used Standards.....	22
10	Signal Outputs.....	22
10.1	Analog Output.....	22
10.2	Modbus Interface .....	22
10.3	Connection between S230/S231 Outputs and Customer Equipment. .	25
11	Optional Extra Accessories.....	26
11.1	Measuring Chambers .....	26
11.2	Service Kit.....	26
12	Calibration.....	26

13 Maintenance.....27  
14 Disposal or Waste.....27

## 1 Safety Instructions

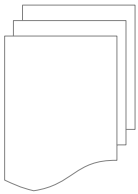

**Please check if this instruction manual matches with the product type.**

Please observe all notes and instructions indicated in this manual. It contains essential information which must be observed before and during installation, operation and maintenance. Therefore this instruction manual must be read carefully by the technician as well as by the responsible user / qualified personnel.

This instruction manual must be available at the operation site of the dew point transmitter at any time. In case of any obscurities or questions, regarding this manual or the product, please contact the manufacturer.



**This document contains important information for the installation and operation of the dew point transmitter in explosive environments (See chapter 8). Please read the instructions carefully and follow the instructions mentioned in this manual.**

- Do not exceed the maximum permitted pressure range (see sensors label).
- The installation and the supply connection must be done in compliance with national regulations.
- The compliance with all of the technical data of the device is mandatory (see also nameplate).
- When opening the enclosure make sure that no dust or moisture enters into the casing.
- Ensure that cable entries are tightly sealed
- Materials which come in contact with the medium are of stainless steel and of sealing rubber NBR.



**WARNING!**

**Compressed air!**

**Any contact with quickly escaping air or bursting parts of the compressed air system can lead to serious injuries or even death!**

- Do not use S230 / S231 in hazardous environment without the optional hazardous approval rating.
- Do not exceed the maximum permitted pressure range (see sensors label).
- Only use pressure tight installation material.
- Avoid that persons get hit escaping air or bursting parts of the instrument.
- The system must not be pressurized during maintenance work.
- Consider all regulations for electrical installations.
- The system must be disconnected from any power supply during maintenance work.
- Any electrical work on the system is only allowed by authorized qualified personal.

**ATTENTION!****Permitted operating parameters!**

**Observe the permitted operating parameters, any operation exceeding this parameters can lead to malfunctions and may lead to damage on the instrument or the system.**

- Do not exceed the permitted operating parameters.
- Make sure the product is operated in its permitted limitations.
- Do not exceed or undercut the permitted storage and operation temperature and pressure.
- The product should be maintained and calibrated frequently, at least annually.

**General safety instructions**

- It is not allowed to use the product S230 / S231 in explosive areas.
- Please observe the national regulations before/during installation and operation.

**Remarks**

- It is not allowed to disassemble the product.
- Always use spanner to mount the product properly.



**ATTENTION!**

**Measurement values can be affected by malfunction!**

**The product must be installed properly and frequently maintained, otherwise it may lead to wrong measurement values, which can lead to wrong results.**

**Storage and transportation**

- Make sure that transportation temperature of the device is between -30 ... +70°C.
- For storage and transportation it is recommended to use the packaging which comes with the device.
- Please make sure that the storage temperature of the device is between 0 ... +50°C.
- Avoid direct UV and solar radiation during storage.
- For the storage the humidity must be <95% rH, no condensation.

**2 Registered Trademarks**

SUTO®

Registered trademark of SUTO iTEC

MODBUS®

Registered trademark of the Modbus Organization, Hopkinton, USA

HART®

Registered trademark of the HART Communication Foundation, Austin, USA

### 3 RF Exposure Information and Statement

This equipment complies with FCC RF radiation exposure limits set forth for an uncontrolled environment. This equipment should be installed and operated with minimum distance of 20 cm between the radiator and your body.

This device complies with part 15 of the FCC rules. Operation is subject to the following two conditions: (1) this device may not cause harmful interference, and (2) this device must accept any interference received, including interference that may cause undesired operation.

**NOTE:** The manufacturer is not responsible for any radio or TV interference caused by unauthorized modifications to this equipment. Such modifications could void the user's authority to operate the equipment.

**NOTE:** This equipment has been tested and found to comply with the limits for a Class B digital device, pursuant to part 15 of the FCC Rules. These limits are designed to provide reasonable protection against harmful interference in a residential installation. This equipment generates uses and can radiate radio frequency energy and, if not installed and used in accordance with the instructions, may cause harmful interference to radio communications. However, there is no guarantee that interference will not occur in a particular installation. If this equipment does cause harmful interference to radio or television reception, which can be determined by turning the equipment off and on, the user is encouraged to try to correct the interference by one or more of the following measures:

- Reorient or relocate the receiving antenna.
- Increase the separation between the equipment and receiver.
- Connect the equipment into an outlet on a circuit different from that to which the receiver is connected.
- Consult the dealer or an experienced radio/TV technician for help.
- This device and its antenna(s) must not be co-located or operating in conjunction with any other antenna or transmitter.



## 4 Application

The S230/S231/S230 Ex/S231 Ex is a dew point transmitter which is designed to monitor the dew point in hazardous environments and industrial application within the permissible operating parameters.

The S230/S231/S230 Ex/S231 Ex measures the following values:

- Dew point of the compressed air or gas.
- Temperature of the compressed air or gas.
- Other selectable moisture units such as: relative humidity [% rH], absolute humidity [ $\text{g}/\text{m}^3$ ,  $\text{mg}/\text{m}^3$ ], humidity grade [g/kg], humidity ratio by volume [ppm<sub>v</sub>] of the compressed air or gas.

The default factory settings are: temperature in °C and dew point in °C Td. Other units can be programmed by the service kit.

## 5 Features

- Double sensor technology for best accuracy over the whole range from -100°C ... +20°C Td dew point in S230 and S230 Ex.
- Robust industrial design.
- Outputs: 1 x 4 ... 20 mA, RS-485 (Modbus).
- IP67 casing provides robust protection in rough industrial environment.
- Very fast response time ensures safe and reliable indication whenever dew points are out of valid ranges.
- High accuracy.

## 6 Technical Data

### 6.1 General

CE FC	
Parameters	Dew point: °C Td or °F Td Temperature: °C or °F Other moisture units: <ul style="list-style-type: none"> <li>- Relative humidity [% rH]</li> <li>- Absolute humidity [g/m<sup>3</sup>, mg/m<sup>3</sup>]</li> <li>- Humidity grade [g/kg]</li> <li>- Humidity ratio by volume [ppm<sub>v</sub>]</li> </ul>
Sensor	S230/S230 Ex: Quartz crystal and polymer sensor S231/S231 Ex: Polymer sensor
Measuring medium	Non-corrosive gases
Measuring range	Dew point: <ul style="list-style-type: none"> <li>• S230/S230 Ex: -100°C Td ... +20°C Td</li> <li>• S231/S231 Ex: -50°C Td ... +20°C Td</li> </ul> Temperature: -30 ... +70°C
Operating pressure	-0.1 ... 1.6 MPa(g) (S230/S230 Ex) -0.1 ... 35 MPa(g) (S231/S231 Ex)
Response time T <sub>90</sub>	< 240 sec (-20 ... -60°C Td) < 30 sec (-60 ... -20°C Td)
Ambient temperature	-20°C ... +50°C
Ambient humidity	0 ... 100% rH
Transport temperature	-30°C ... +70°C
Casing material	Process connection: stainless steel Casing: aluminium alloy
Protection class	IP67
Dimensions	See dimensional drawing on page 13.
Process connection	G ½" thread (ISO 228/1)
Weight	0.4 kg

## 6.2 Electrical Data

Power supply	10 ... 30 VDC / 30 mA
--------------	-----------------------

## 6.3 Output Signals

Analogue output	4 ... 20 mA, isolated
Analogue output scaling (default: dew point)	S230/S230 Ex: 4 mA = -100°C Td 20 mA = +20°C Td S231/S231 Ex: 4 mA = -50°C Td 20 mA = +20°C Td
RS-485	Modbus/RTU

## 6.4 Accuracy

Accuracy	Dew point: see chart below Temperature: 0.3°C
Repeatability	± 1.0°C Td
Stated accuracy at	Ambient/process temperature: 23°C ± 3°C Ambient/process humidity <95% rH, no condensation Airflow > 2 l/min at sensor tip

Accuracy:

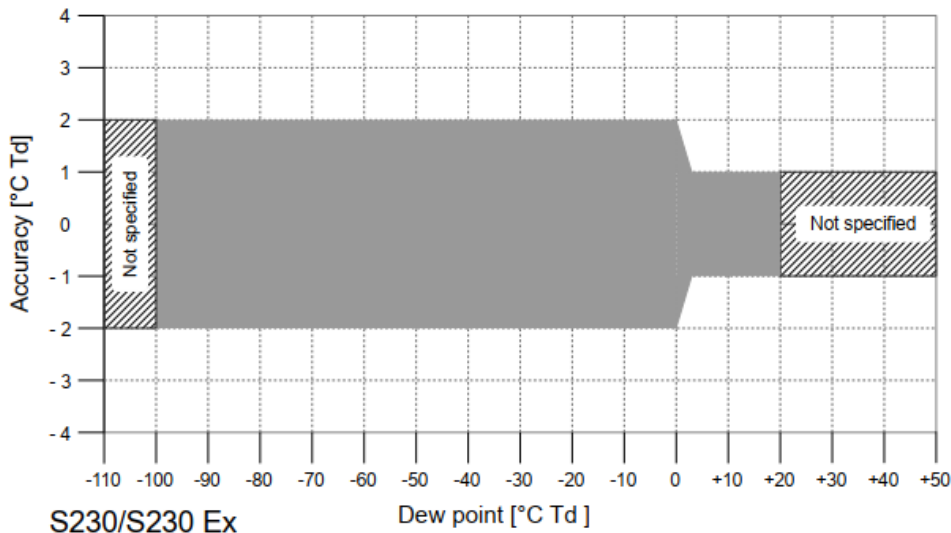

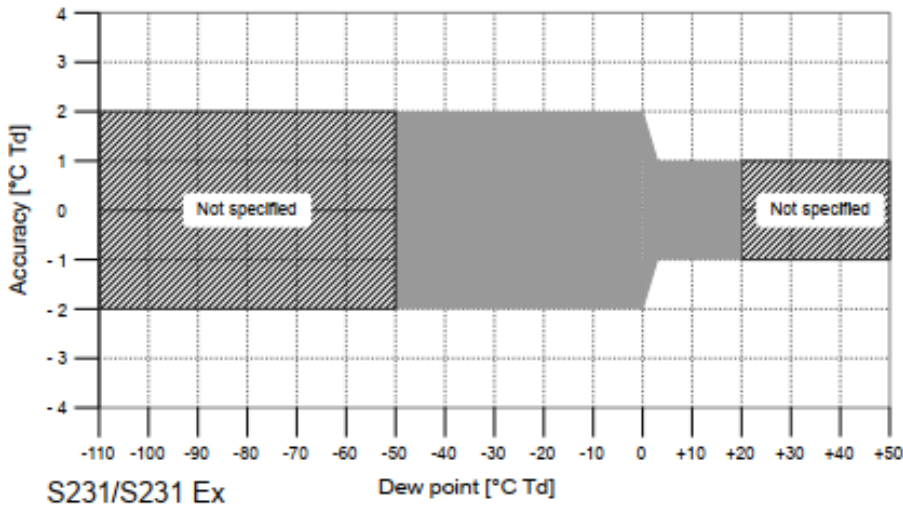

Valid range:

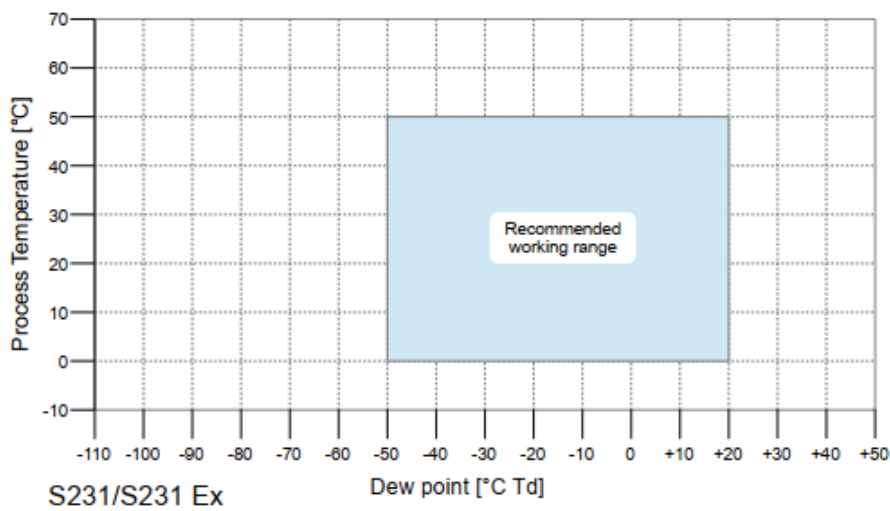
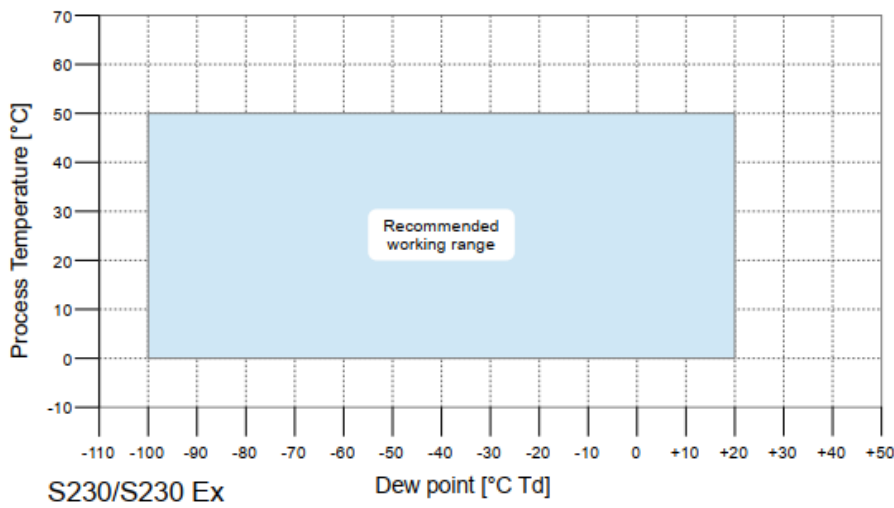

## 7 Dimensional Drawing

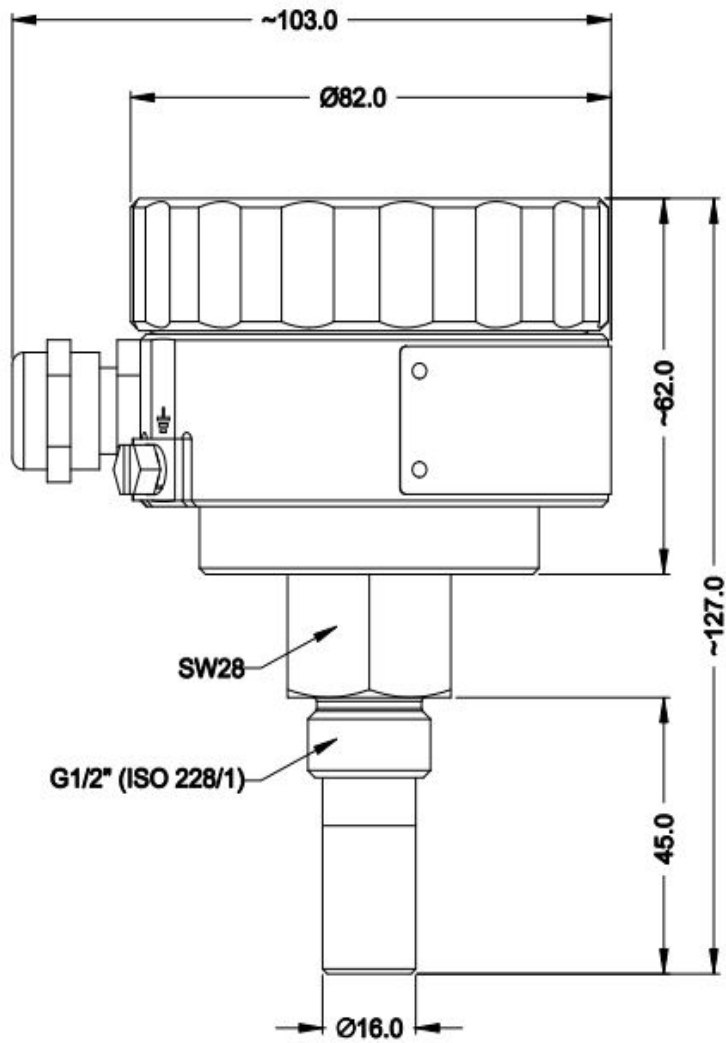

## 8 Installation

### 8.1 General Installation Considerations

- The Dew Point Transmitter is only allowed to be used in the permitted temperature class.
- Cables, drain plugs, cable glands and cable entries must be suitable and certified.

### 8.2 Medium Temperature



#### **ATTENTION!**

**The minimum temperature for compressed air or gas is  $-30^{\circ}\text{C}$ .**

### 8.3 Cable Entries

The cable glands/entries must be secured to prevent working loose and the seals must be installed immediately adjacent to the casing.

Please ensure that the cable entries and cable glands are leak-tight!

The cables used must be manufactured in a way that the build-up of electrostatic charges are avoided!

### 8.4 Fuse

The power supply for the transmitter needs to have a fuse with following specification:

Voltage 16 to 30 VDC, fuse 0.5 A slow blow (cutoff capacity 1500 A)

### 8.5 Determination of the Installation Point

In order to maintain the accuracy stated in the technical data, the device must be installed correctly. The air must flow on to the sensor tip, otherwise it will lead to wrong measurement values. For further instructions, please read the next chapter carefully.

Please consider that enough space exists at your site for a adequate installation as described in this manual.

**ATTENTION!**

**Wrong measurement is possible, if the device is not installed correctly.**

**It is strongly recommend not to install S230/S231/S230 Ex/S231 Ex permanently in wet applications such as the compressor outlet.**

**8.6 Installation Requirements**

The flowing air or gas must pass the sensor tip for a proper measurement. This can be realized with a measurement chamber. For a installation without measuring chamber you need to concern the installation depth which is described in the next chapter.

**8.7 Installation to Compressed Air / Gas**

The following steps explain the procedure of an appropriate installation.

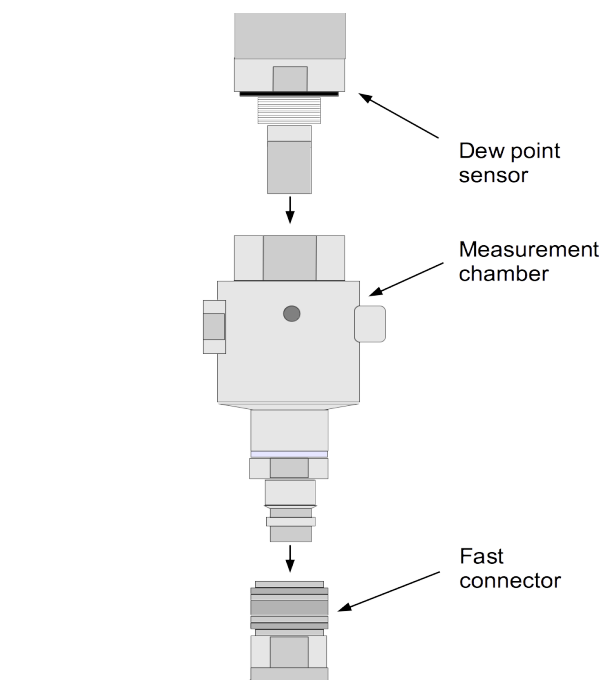
**Install the device with measurement chamber**

1. Connect the device with the measurement chamber.
2. Connect the device and the measurement chamber with the fast connector.

**Attention:**

For explosive gas application, installation with measurement chamber is not allowed!

### Install the device without measurement chamber

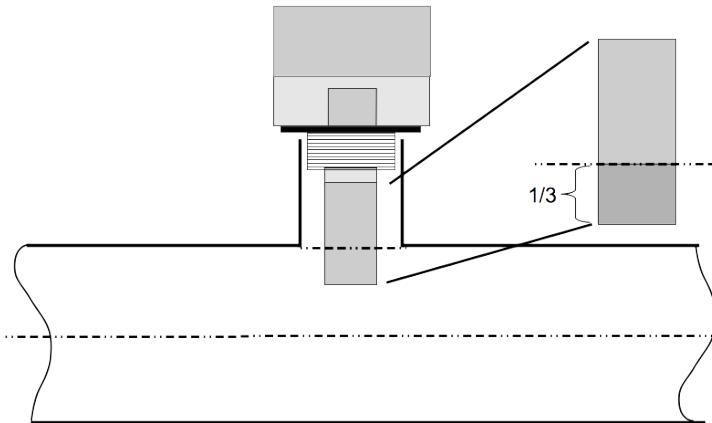

- Install the device only if the system is not pressurized.
- Not less than 1/3 of the sensor tip should be inside of the pipe. For this please check the size of the nozzle.
- The inner thread must be G 1/2".

### Remarks

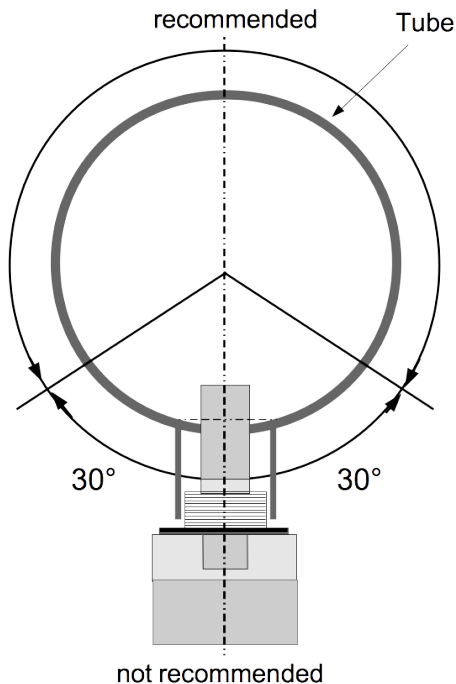

Please install the transmitter only in the recommended area as you can see in the picture. An upside down installation is not permitted. Please consider that the distance to the vertical level must be  $>30^\circ$ .

### Removal of the device

To remove the transmitter unscrew the transmitter from the measurement chamber or from the nozzle. Please observe that the system is not pressurized when the transmitter is removed.



## 8.8 Electrical Connection

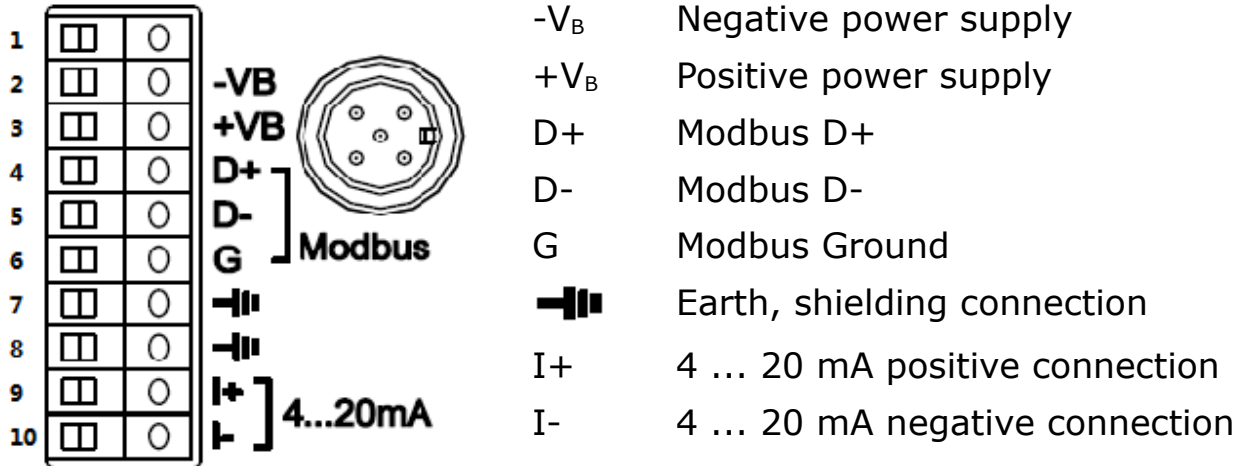

## 9 Ex Version S230 Ex/S231 Ex

### 9.1 Special Conditions for the Ex Version

- Ambient temperature range between 0°C and +50°C.
- Do not separate when energized.
- Do not open in hazardous area.
- Integration into the potential equalization is carried out via the installation.
- The device must only be operated with a fuse with a 1500 A cut-off capacity.
- The operating instructions must be observed.
- The intrinsically safe maximum values can be found in Section 7.3.



#### Special Attention!

Integration into the potential equalization is carried out via the installation.

The device must be connected to the potential equalization system.

## 9.2 Examination Certificates, Certificate of Conformity

The system meets the fundamental health and safety requirements for the design and construction of devices and protective systems intended for use in potentially explosive atmospheres in accordance with directive 2014/34/EU.

## 9.3 Intrinsic Safety Ratings and Parameters

Electrical parameters supply and signal circuit in type of protection intrinsic safety Ex ib IIC:

- Maximum input power ( $P_i$ ): 1 W
- Maximum input voltage ( $U_i$ ): 30 V
- Maximum input current ( $I_i$ ): 30 mA
- Maximum effective internal inductance ( $L_i$ ): 220  $\mu$ H
- Maximum effective capacity ( $C_i$ ): 13  $\mu$ F

## 9.4 Name Plates

Below are the name plates when ordered with hazardous approval.

### ATEX:

Manufacturer: SUTO iTEC (China) Co.Ltd.

Address: No. 1001 Zhongshanyuan Rd., Nanshan, Shenzhen, PRC

○	<b>S230 Ex</b>	○
	Item number : S699 0230 Serial number : 2717 0001 Supply : 10 ... 30 VDC, 1 W Tmed : -30 ... +70 °C (T4) Tamb : -20 ... +50 °C Max. pressure : 1.6 MPa(g) Range TD : -100 ... +20 °C Td	
	SUTO iTEC (China) Co. Ltd. No. 1001 Zhongshanyuan Rd., Nanshan, Shenzhen, PRC	○
	II 2G Ex db [ib] IIC T4 Gb PTZ 18 ATEX0034 X 	○
	<b>Caution!</b> - Please read instruction manual before working on device. - The device should be opened in a non-explosive atmosphere or in a de-energized state where a delay of 5 minutes after power down has to be ensured.	○

○	<b>S231 Ex</b>	○
	Item number : S699 0231 Serial number : 2717 0001 Supply : 10 ... 30 VDC, 1 W Tmed : -30 ... +70 °C (T4) Tamb : -20 ... +50 °C Max. pressure : 35 MPa(g) Range TD : -50 ... +20 °C Td	
	SUTO iTEC (China) Co. Ltd. No. 1001 Zhongshanyuan Rd., Nanshan, Shenzhen, PRC	○
	II 2G Ex db [ib] IIC T4 Gb PTZ 18 ATEX0034 X 	○
	<b>Caution!</b> - Please read instruction manual before working on device. - The device should be opened in a non-explosive atmosphere or in a de-energized state where a delay of 5 minutes after power down has to be ensured.	○

**IECEX:**

Manufacturer: SUTO ITEC (China) Co.Ltd.

Address: No. 1001 Zhongshanyuan Rd., Nanshan, Shenzhen, PRC

○	<p><b>S230 Ex</b>                  Item number : S699 0230                  Serial number : 2717 0001                  Supply : 10 ... 30 VDC, 1 W                  Tmed : -30 ... +70 °C (T4)                  Tamb : -20 ... +50 °C                  Max. pressure : 1.6 MPa(g)                  Range TD : -100 ... +20 °C Td</p>	<p><b>SUTO ITEC (China) Co. Ltd.</b>                  No. 1001 Zhongshanyuan Rd.,                  Nanshan, Shenzhen, PRC</p>	 www.suto-itec.com	○
		<p>Ex db [ib] IIC T4 Gb                  IECEX CQM 18.0007X</p> <p style="text-align: center;"><b>CE</b></p>	<p><b>Caution!</b>                  - Please read instruction manual before working on device.                  - The device should be opened in a non-explosive atmosphere or in a de-energized state where a delay of 5 minutes after power down has to be ensured.</p>	

○	<p><b>S231 Ex</b>                  Item number : S699 0231                  Serial number : 2717 0001                  Supply : 10 ... 30 VDC, 1 W                  Tmed : -30 ... +70 °C (T4)                  Tamb : -20 ... +50 °C                  Max. pressure : 35 MPa(g)                  Range TD : -50 ... +20 °C Td</p>	<p><b>SUTO ITEC (China) Co. Ltd.</b>                  No. 1001 Zhongshanyuan Rd.,                  Nanshan, Shenzhen, PRC</p>	 www.suto-itec.com	○
		<p>Ex db [ib] IIC T4 Gb                  IECEX CQM 18.0007X</p> <p style="text-align: center;"><b>CE</b></p>	<p><b>Caution!</b>                  - Please read instruction manual before working on device.                  - The device should be opened in a non-explosive atmosphere or in a de-energized state where a delay of 5 minutes after power down has to be ensured.</p>	

## 9.5 Installation

### 9.5.1 General Installation Considerations

Cables and pipe entries must be certified (Ex d IIC) and must be suitable for operating temperatures of up to 105°C. When using pipe entries, the associated sealing equipment must be fitted directly at the housing.

### 9.5.2 Cable Entries

The cable glands/entries must be secured to prevent working loose and the seals must be installed immediately adjacent to the casing.

Please ensure that the cable entries and cable glands are leak-tight!

The cables used must be manufactured in a way that the build-up of electrostatic charges are avoided!

Only following cable gland is allowed to be used and can be ordered at SUTO:

	<b>Hummel Order No.</b>	<b>Description</b>	<b>Thread size</b>	<b>Cable entry</b>
Gland	1.622.1600.50	HSK-M-Ex-d/Metr	M16 x 1.5	5 ... 10 mm

Cable outer diameter must be between 5.0 ... 10 mm!

## 9.6 Potential Equalization

For the safety of the operation in explosive environment the potential equalization is very important. The device has a screw terminal outside the enclosure to connect the earth signal.

The device can also be integrated to the equalization through the pipeline as long the earth connection is conform to regulations.

## 9.7 Service Kit

No connection of service-kit or any other devices are permitted if the atmosphere is considered to be explosive.

Alternatively device settings can be done through the Modbus interface from a remote location (non-explosive area) if the cable is installed.

Please contact our service for available devices and software.

## 9.8 Back Cover / Security Seal

The Back cover of the device is secured with a screw to avoid the opening of the cover by unauthorized persons. Please ensure that the security screw is tighten up after finishing the installation!

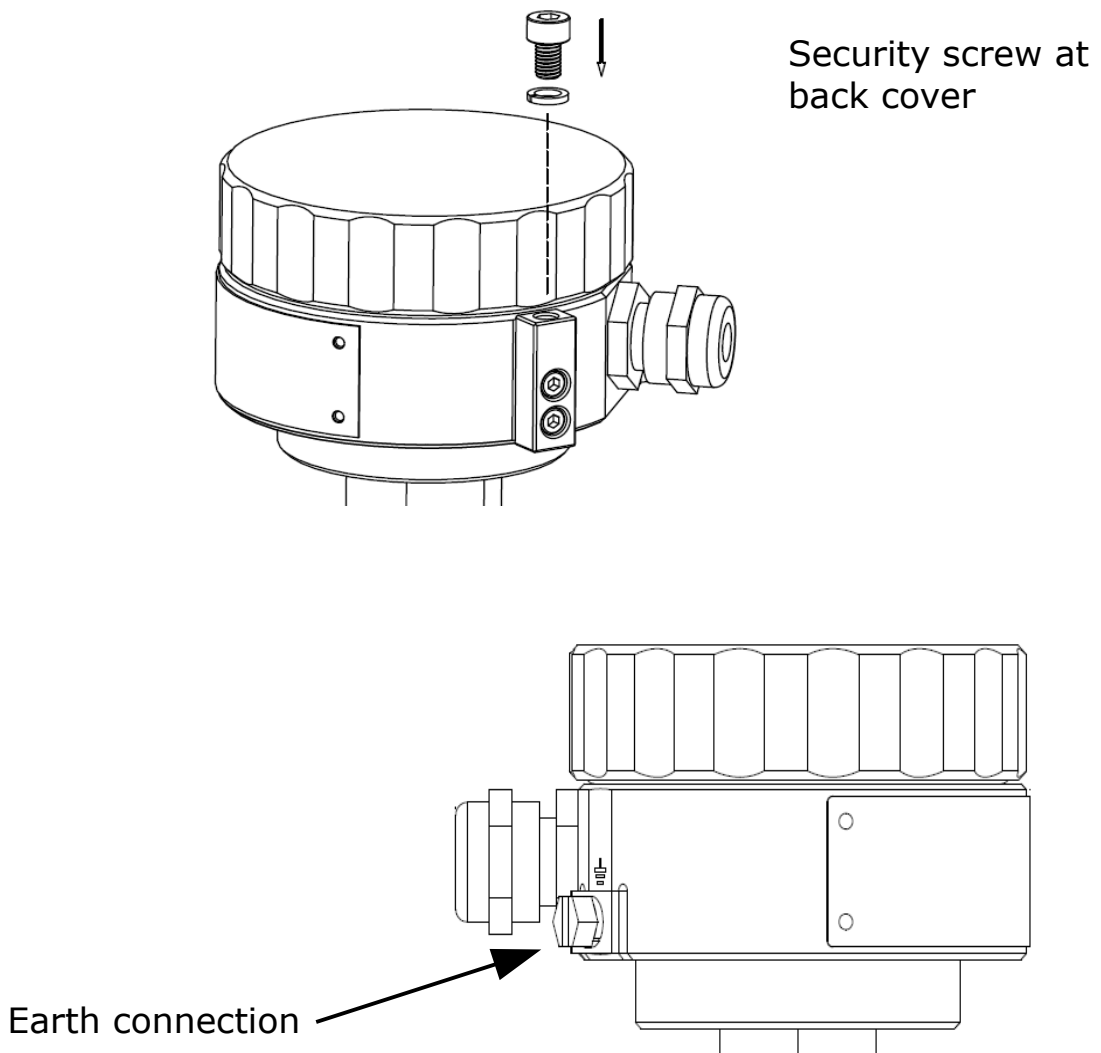

## 9.9 Used Standards

### ATEX:

EN 60079-0:2017  
 EN 60079-1:2014  
 EN 60079-11:2012

### IECEX:

IEC 60079-0:2017  
 IEC 60079-1:2014  
 IEC 60079-11:2011

## 10 Signal Outputs

### 10.1 Analog Output

The device has an analog output range of 4 ... 20 mA. The signal is isolated from the power supply. This output is scaled to:

	<b>S230/S230 Ex</b>	<b>S231/S231 Ex</b>
4 mA	-100°C Td	-50°C Td
20 mA	+20°C Td	+20°C Td

Ex factory the dew point signal is routed to the analogue output. However the user can choose other moisture signals to be used instead. Contact our service for assistance.

### 10.2 Modbus Interface

Mode : RTU  
 Baud rate : 19200  
 Device address : Last two digits of the serial number  
 Framing / parity / stop bit : 8, N, 1  
 Response time : 1 second  
 Response delay : 0 ms  
 Inter-frame spacing : 7 char

Response message that the device returns to the master:

- Function code: 03

The information for the byte order is shown in the table below:

Byte Order	Sequence				Data Type
	1st	2nd	3rd	4th	
1-0-3-2	Byte 1 (MMMMMMMM*)	Byte 0 (MMMMMMMM *)	Byte 3 (SEEEEEEE)	Byte 2 (EMMMMMMM *)	FLOAT
1-0-3-2	Byte 1	Byte 0 LSB	Byte 3 MSB	Byte 2	UINT32 INT32
1-0	Byte 1 MSB	Byte 0 LSB	---	---	UINT16 INT16
1-0	Byte 1 XXX *	Byte 0 DATA	---	---	UINT8 INT8

\* S: Sign, E: Exponent, M: Mantissa, XXX: no value

**Note:** If your application needs other Modbus settings, please state it in the order. Modbus communication settings as well as other settings can be changed by the service App **S4C-DP** or through the windows based **Service Software**.

#### Available measurement channels:

Holding register	Channel description	Format
1	Temperature	FLOAT
3	Relative humidity	FLOAT
5	Reserved	FLOAT
7	Pressure dew point	FLOAT
9	Alternative measurement unit	FLOAT
41	Temperature unit	INTEGER
43	Relative humidity unit	INTEGER
45	Reserved	INTEGER
47	Pressure dew point unit	INTEGER
49	Alternative humidity unit	INTEGER
51	Status	INTEGER

**Notes:**

- Data length is always 4 Byte
- FLOAT representation according to IEEE 754
- The physical units are coded according to the table below
- Status definition:
  - Bit2        DP over range
  - Bit3        Temperature over range
  - Bit6        Calibration overdue
  - Bit7        EEPROM broken
  - Bit8        DP sensor broken
  - Bit10       QCM sensor broken
  - Bit11       NTC broken

**Unit Table**

Temperature in °C	1	Absolute humidity in mg/m <sup>3</sup>	7
Temperature in °F	2	Mixing ration in g/kg	8
Relative humidity in % rH	3	Absolute humidity in g/m <sup>3</sup>	9
Dew point in °C Td	4	Parts per million in ppm <sub>v</sub>	30
Dew point in °F Td	5	Atmospheric dew point in °C Td	31
Mixing ratio in mg/kg	6	Atmospheric dew point in °F Td	32



### 10.3 Connection between S230/S231 Outputs and Customer Equipment

This section provides figures to show how outputs supported by the S230/S231 or S230 Ex/S231 Ex connect with the customer equipment.

In the following figures, the **SUTO Instrument** indicates the S230/S231 or S230 Ex/S231 Ex.

Isolated 4 ... 20 mA  
analog output

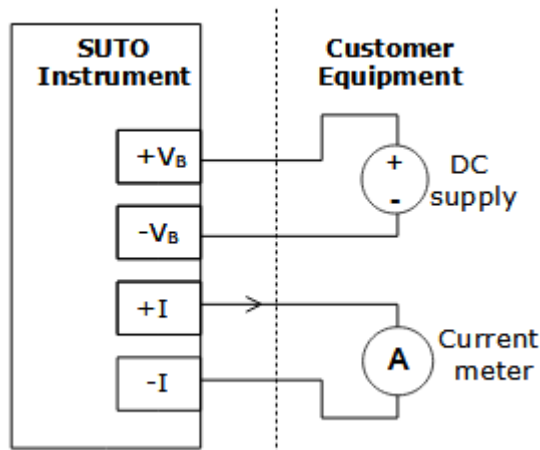

Modbus/RTU output

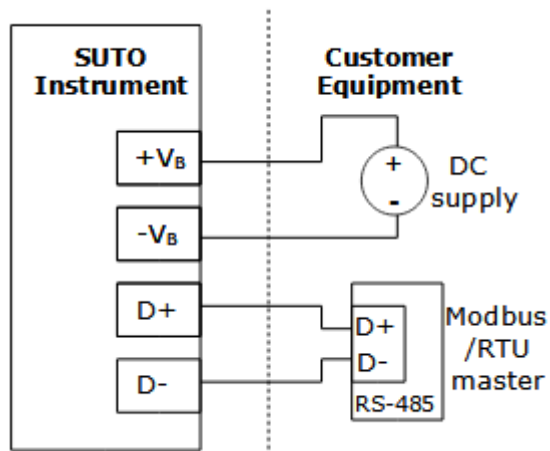

## 11 Optional Extra Accessories

### 11.1 Measuring Chambers

There are different types of measuring chambers for example Measuring chamber with fast connector, by-pass-by chamber with in and out connection, measuring chamber for dryer installation or high pressure chamber. For more information please contact your retailer or the manufacturer.

### 11.2 Service Kit

The service kit is used to connect the device with the PC. The device parameters such as analogue output scaling, alarm values, units etc. can be easily changed by using the service kit.

The diagram below shows the connection when using the optional service kit. In case the device is connected with power supply and Modbus to a master device, **please remove the Modbus connection.** first before connecting the service kit.

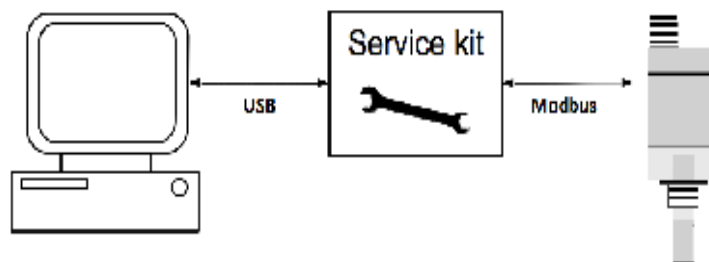

## 12 Calibration

The instrument is calibrated ex work. The exact calibration date is printed on the certificate which is supplied together with the instrument. The accuracy of the instrument is regulated by the on site conditions, parameters like oil, high humidity or other impurities can affect the calibration and furthermore the accuracy. However we recommend to calibrate the instrument at least once per year. The calibration is excluded from the instruments warranty. For this please contact the manufacturer.

## 13 Maintenance

Please observe from time to time the sinter cap. If it appears to be dirty, it is recommended to replace it for this please contact the manufacturer.

## 14 Disposal or Waste



Electronic devices are recyclable material and do not belong in the household waste.

The device, the accessories and its packings must be disposed according to your local statutory requirements.

The dispose can also be carried by the manufacturer of the product, for this please contact the manufacturer.

---

## SUTO iTEC GmbH

Grißheimer Weg 21  
D-79423 Heitersheim  
Germany

Tel: +49 (0) 7634 50488 00  
Email: [sales@suto-itec.com](mailto:sales@suto-itec.com)  
Website: [www.suto-itec.com](http://www.suto-itec.com)

## SUTO iTEC (ASIA) Co., Ltd.

Room 10, 6/F, Block B, Cambridge Plaza  
188 San Wan Road, Sheung Shui, N.T.  
Hong Kong

Tel: +852 2328 9782  
Email: [sales.asia@suto-itec.com](mailto:sales.asia@suto-itec.com)  
Website: [www.suto-itec.com](http://www.suto-itec.com)

## SUTO iTEC Inc.

5460 33rd St SE  
Grand Rapids, MI 49512  
USA

Tel: +1 (616) 800-7886  
Email: [sales.us@suto-itec.com](mailto:sales.us@suto-itec.com)  
Website: [www.suto-itec.com](http://www.suto-itec.com)

---

All rights reserved ©

Modifications and errors reserved

S230\_231\_im\_en\_2022-2