

Instruction and Operation Manual

S211/S215/S220

Dew Point Transmitter



Dear Customer,

Thank you for choosing our product.

The operating instructions must be read in full and carefully observed before starting up the device. The manufacturer cannot be held liable for any damage which occurs as a result of non-observance or non-compliance with this manual.

Should the device be tampered with in any manner other than a procedure which is described and specified in the manual, the warranty is cancelled and the manufacturer is exempt from liability.

The device is destined exclusively for the described application.

SUTO offers no guarantee for the suitability for any other purpose. SUTO is also not liable for consequential damage resulting from the delivery, capability or use of this device.

Table of contents

1 Safety Instructions.....	4
2 Registered Trademarks.....	6
3 Application.....	7
4 Features.....	7
5 Technical Data.....	8
5.1 General.....	8
5.2 Electrical Data.....	9
5.3 Output Signals.....	9
5.4 Accuracy	10
6 Dimensional Drawing.....	11
7 Determination of the Installation Point.....	13
8 Installation	14
8.1 Installation Requirements.....	14
8.2 Installation Procedure	15
8.3 Electrical Connection	19
8.4 Connection between S211/S215/S220 and Customer Equipment	20
9 Signal Outputs.....	22
9.1 Analog Output	22
9.1.1 Scaling.....	22
9.2 Modbus/RTU Interface	22
9.2.1 Holding Register Table for Modbus/RTU	23
9.2.2 Connect Modbus/RTU Devices to a Master.....	26
10 Optional Accessories.....	30
10.1 Measuring Chambers	30
10.2 Service Kit.....	30
11 Calibration.....	30
12 Maintenance.....	31
13 Disposal or Waste.....	31

1 Safety Instructions

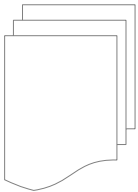

Please check if this instruction manual matches with the product type.

Please observe all notes and instructions indicated in this manual. It contains essential information which must be observed before and during installation, operation and maintenance. Therefore this instruction manual must be read carefully by the technician as well as by the responsible user or qualified personnel.

This instruction manual must be available at the operation site of the Dew Point Transmitter at any time. In case of any obscurities or questions, regarding this manual or the product, please contact the manufacturer.

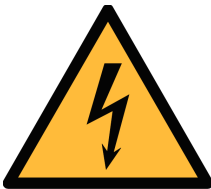

WARNING!

Compressed air!

Any contact with quickly escaping air or bursting parts of the compressed air system can lead to serious injuries or even death!

- Do not exceed the maximum permitted pressure range (see sensors label).
- Only use pressure tight installation material.
- Avoid that persons get hit escaping air or bursting parts of the instrument.
- The system must be pressure-less during maintenance work.



WARNING!

Voltage used for supply!

Any contact with energized parts of the product, may lead to a electrical shock which can lead to serious injuries or even death!

- Consider all regulations for electrical installations.
- The system must be disconnected from any power supply during maintenance work.
- Any electrical work on the system is only allowed by authorized qualified personal.



ATTENTION!

Permitted operating parameters!

Observe the permitted operating parameters, any operation exceeding this parameters can lead to malfunctions and may lead to damage on the instrument or the system.

- Do not exceed the permitted operating parameters.
- Make sure the product is operated in its permitted limitations.
- Do not exceed or undercut the permitted storage and operation temperature and pressure.

General safety instructions

- It is not allowed to use the product in explosive areas.
- Please observe the national regulations before/during installation and operation.

Remarks

- It is not allowed to disassemble the product.
- Always use spanner to mount the product properly.



ATTENTION!

Measurement values can be affected by malfunction!

The product must be installed properly and frequently maintained, otherwise it may lead to wrong measurement values, which can lead to wrong results.

Storage and transportation

- Make sure that the transportation temperature of the instrument is between -30 ... +70°C.
- For transportation it is recommended to use the packaging which comes with the instrument.
- Please make sure that the storage temperature of the instrument is between -20 ... +50°C.
- Avoid direct UV and solar radiation during storage.
- For the storage the humidity must be <95% rH, no condensation.

2 Registered Trademarks

SUTO®

Registered trademark of SUTO iTEC

MODBUS®

Registered trademark of the Modbus Organization, Hopkinton, USA

HART®

Registered trademark of the HART Communication Foundation, Austin, USA

3 Application

The S211 / S215 / S220 are three industrial Dew Point Transmitters designed for measuring dew point and related parameters in compressed air or industrial gases under specified operating conditions (See next page).

Parameter	Default unit
Temperature	°C
Humidity	% rH
Dew point	°C Td
Pressure (optional)	bar(g)

Remark: You can change the units using the service kit (optional) and the S4C-DP software.

The S211 / S215 / S220 Dew Point Transmitters are mainly used in compressed air systems in the industrial environment, and not developed to be used in explosive areas. To use them in explosive areas, contact the manufacturer.

4 Features

- Three Dew Point Transmitter models applicable for different measuring ranges:
 - S211 measures down to -60°C Td
 - S215 measures down to -20°C Td
 - S220 measures down to -100°C Td
- Optional display for on-site values. The display can be rotated 340° horizontally to ease your access to readings.
- Various signal output options: 4 ... 20 mA 2-wire, 4 ... 20 mA 3-wire, or 4 ... 20 mA 3-wire + Modbus/RTU.
- Optional integrated pressure sensor.
- IP65 casing provides robust protection in rough industrial environment.
- Very fast response time ensures safe and reliable indication whenever dew points are out of valid ranges.
- High accuracy of $\pm 2^\circ\text{C}$ Td dew point.

5 Technical Data

5.1 General

CE	
Parameters	Standard unit dew point: °C Td Standard unit temperature: °C other units: °F, K Standard unit humidity: % rH Standard unit pressure: bar (g)
Principle of measurement	Capacitive method and frequency method
Measuring range	Type Range
	S215 Dew point : -20 ... +50°C Td Relative Humidity : 0 ... 90 % rH Temperature : -30 ... +70°C Pressure (option) : 0 ... 1.6 MPa
	S211 Dew point : -60 ... +20°C Td Relative Humidity : 0 ... 90 % rH Temperature : -30 ... +70°C Pressure (option) : 0 ... 1.6 MPa
S220 Dew point : -100 ... +20°C Td Relative Humidity : 0 ... 90 % rH Temperature : -30 ... +70°C Pressure (option) : 0 ... 1.6 MPa	
Sensor	S215 / S211: Polymer S220: QCM + Polymer Temperature sensor: Pt100 Pressure sensor: Piezo resistive type
Measuring medium	Air, Argon, O ₂ , N ₂ , CO ₂ *
Response time (T ₉₀) @4 l/min	S215 0 °C Td → -20 °C Td ≤ 50 sec -20 °C Td → 0 °C Td) ≤ 35 sec
	S211 0 °C Td → -60 °C Td ≤ 280 sec -60 °C Td → 0 °C Td ≤ 65 sec
	S220 0 °C Td → -80 °C Td ≤ 420 sec -80 °C Td → 0 °C Td ≤ 90 sec

Ambient temperature	0 ... +50°C
Ambient humidity	0 ... 95% rH
Operating pressure	-0.1 ... 1.6 MPa -0.1 ... 35.0 MPa optional for S215 / S211
Casing material	Casing: Aluminium alloy Process thread: Stainless steel 1.4301 (SUS 304) Display cover: PC + ABS
Protection class	IP65
Display (optional)	0.66" OLED display for displaying the measured value and unit 340° horizontally rotatable**
Dimensions	See dimensional drawing on the page 11
Screwing thread	G ½" thread (ISO 228/1)
Weight	180 g
* For CO ₂ , the measurement range of S211 is limited to -40°C Td ** The rotation force cannot exceed 3.0 N.m	

5.2 Electrical Data

Power supply	15 ... 30 VDC
Current consumption	2-wire: 4 ... 20 mA 3-wire: 40 mA @ 24 VDC 3-wire with display: 50 mA @ 24 VDC

5.3 Output Signals

Analog output	4 ... 20 mA 3-wire or 4 ... 20 mA 2-wire		
Analog output scaling	Type	Scaling	
	S211	4 mA	= -60°C Td
		20 mA	= +20°C Td
	S215	4 mA	= -20°C Td
		20 mA	= +50°C Td
	S220	4 mA	= -100°C Td
20 mA		= +20°C Td	
Modbus output	Modbus/RTU		

Modbus communication	<p>Mode: RTU Baud rate: 19200 Device address: last 2 digits of serial number Framing / parity / stop bit: 8 / N / 1 Response time: 1 second Response delay: 0 ms Interframe spacing: 7 char</p>
----------------------	---

5.4 Accuracy

Accuracy	<p>Dew point: ± 1 °C Td (0 ... 20°C Td) ± 2 °C Td (-70 ... 0 / +20 ... +50 °C Td) ± 3 °C Td (-100 ... -70 °C Td)</p> <p>Temperature: ± 0.3°C</p> <p>Pressure: 0.5% FS</p>
Repeatability of dew point	± 0.5 °C
Stated accuracy at	<p>Ambient/process temperature 23 °C ± 3 °C Ambient/process humidity <95% rH, no condensation Airflow > 2 l/min at sensor tip</p>
Flow rate	<p>In order to reach a fast response time please ensure a flow rate of 2... 5 l/min at the sensor tip.</p> <p>Note: If the Measuring chamber A699 3491 is used, this flow rate will be maintained by the chamber at a pressure > 0.3 MPa.</p>

6 Dimensional Drawing

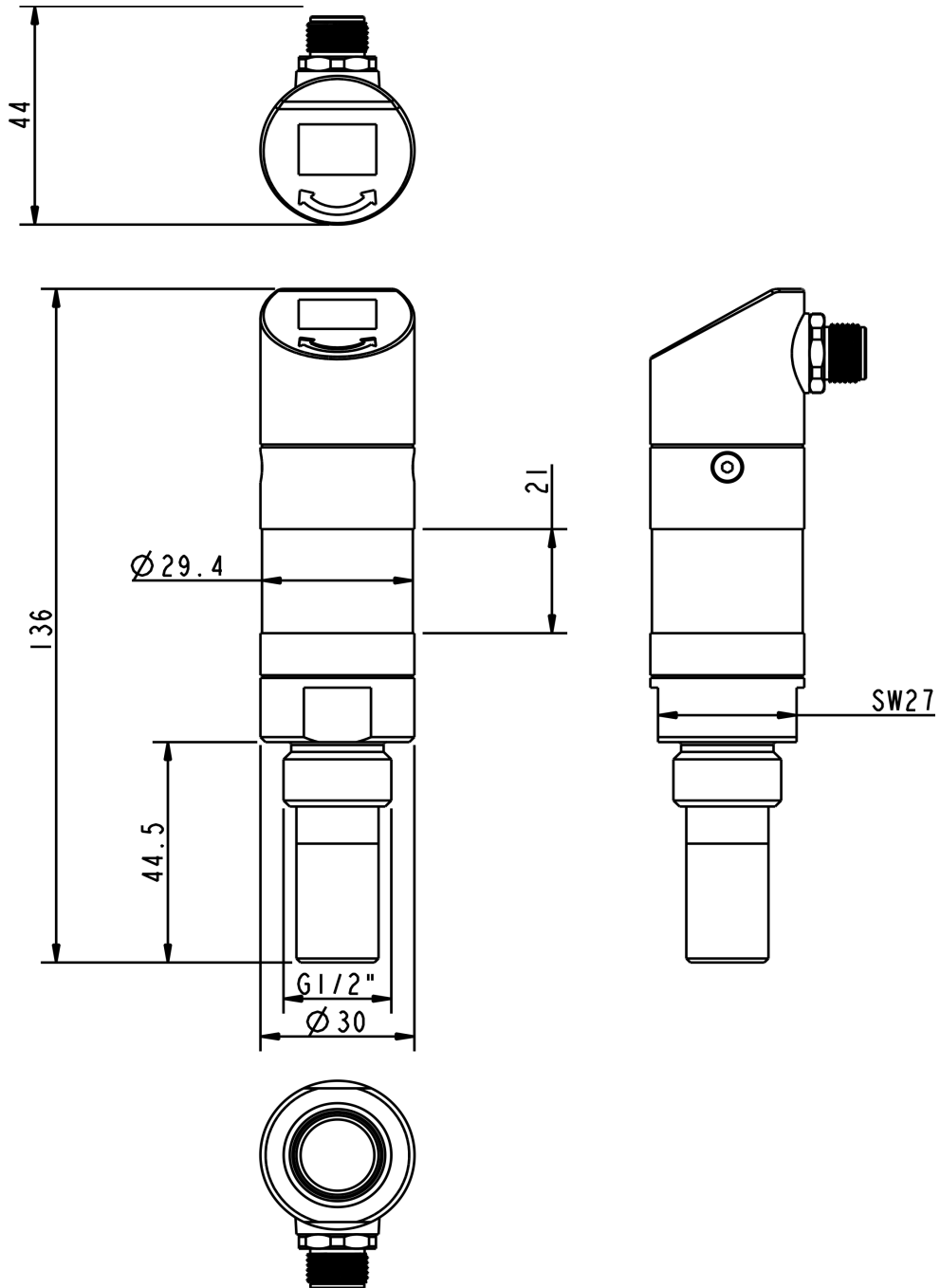

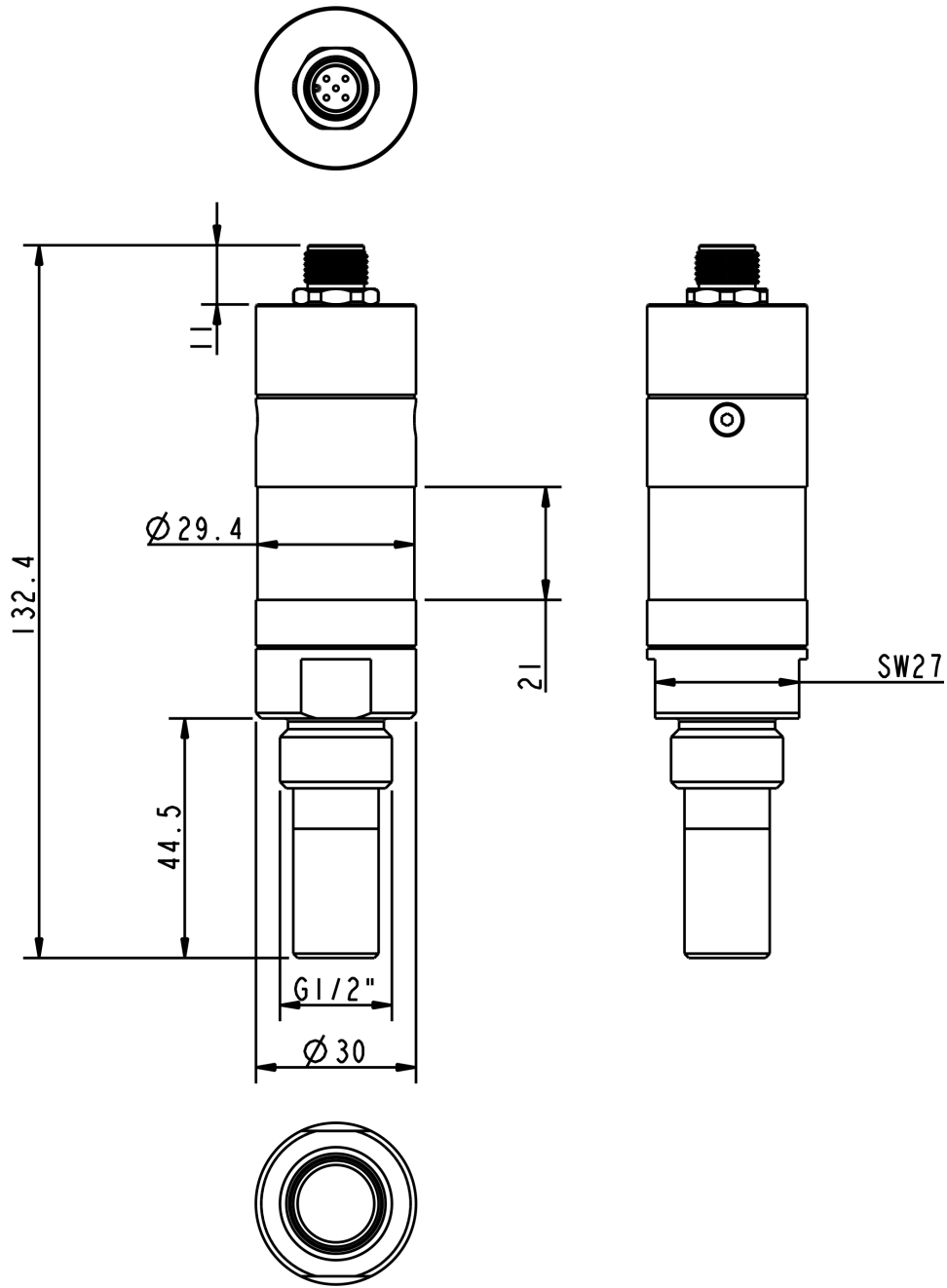

7 Determination of the Installation Point

In order to maintain the accuracy stated in the technical data, the device must be installed correctly. The gas must flow on to the sensor tip, otherwise it will lead to wrong measurement values. For further instructions, please read chapter [8](#) carefully.

Please consider that enough space exists at your site for a convenient installation.



ATTENTION!

Wrong measurement is possible if the instrument is not installed correctly.

- The device is for indoor use only! At an outdoor installation, it must be protected from solar radiation and rain.
- It is strongly recommend not to install S211 / S215 / S220 permanently in wet environment, which usually exists right after a compressor outlet.

8 Installation

Before installing the device, make sure that all components listed below are included in your package.

Qty	Description	Item no. (Model dependent)		
1	Dew Point Transmitter	S215	S211	S220
		S699 1215	S699 1211	S699 1220
		S699 2215	S699 2211	S699 2220
		S699 3215	S699 3211	S699 3220
		S699 4215	S699 4211	S699 4220
1	Depending on orders: M12 plug or M12 cable	Plug: C219 0059 Cable: A553 0104/A553 0105		
1	Instruction manual	No P/N		
1	Calibration certificate	No P/N		

Remark: The item number of the model varies depending on the chosen measurement range and signal output.

8.1 Installation Requirements

The flowing air or gas must pass the sensor tip for a proper measurement. This can be realized with a measurement chamber.

For an installation without the measuring chamber, you must insert the device to the required depth, as described in section [8.2](#).

Remark:

The 3 Dew Point Transmitters models S211, S215 and S220 are offered in different versions. Depending on the version the options might be different, please see below table for an overview about the different models, their signal output and available options.

Dew Point Transmitter versions

S699 1xxx	Dew Point Transmitter with 2-wire analog & SDI output
S699 2xxx	Dew Point Transmitter with 3-wire analog & SDI output
S699 3xxx	Dew Point Transmitter with 3-wire analog & Modbus/RTU output
S699 4xxx	Dew Point Transmitter incl. integrated pressure sensor with 3-wire analog & Modbus/RTU output

Options

A1381	High pressure option 0... 35.0 MPa (only available for S215 & S211, not available for S699 4xxx versions)
A1387	OLED Display option for 3-wire Analog version (only for S699 2xxx)
A1388	OLED Display option for 3-wire Analog & Modbus version (only for S699 3xxx & S699 4xxx)

In any case, if you need support to choose the right model for your application, please feel free to contact SUTO sales support.

8.2 Installation Procedure

The following steps explain the procedure of an appropriate installation.

Installation with the measurement chamber A699 3491

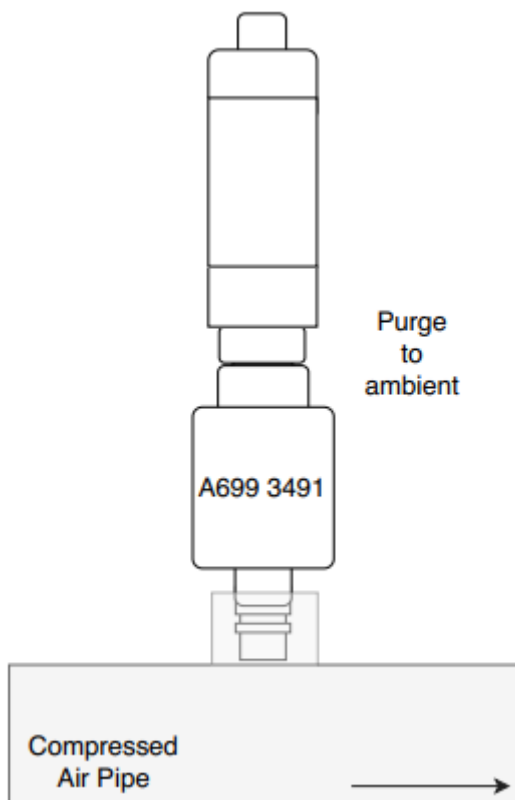

1. Mount the device on the measurement chamber by using the G1/2" connection.
2. Make sure the device is tightly sealed, therefore the sealing ring on the Dew Point Transmitter must be used.
3. Connect the measuring chamber to the compressed air system using a quick connector. Make sure the Dew Point Transmitter is screwed on the chamber before connecting. The measurement chamber will create a purge flow.

Installation with the by-pass measurement chamber A699 3493

For the model A699 3493, there are two installation methods:

Method 1: Full pass through by-pass installation

This method is to be used when the full air flow is passing through the measuring chamber.

1. Connect the inlet of the chamber using a 6 mm teflon hose to your system.

Note: The full flow must pass the measuring chamber. Ensure a certain flow rate to get fast response time.

2. Connect the outlet of the chamber to your system using the 6 mm hose quick connector.

See below figure for details.

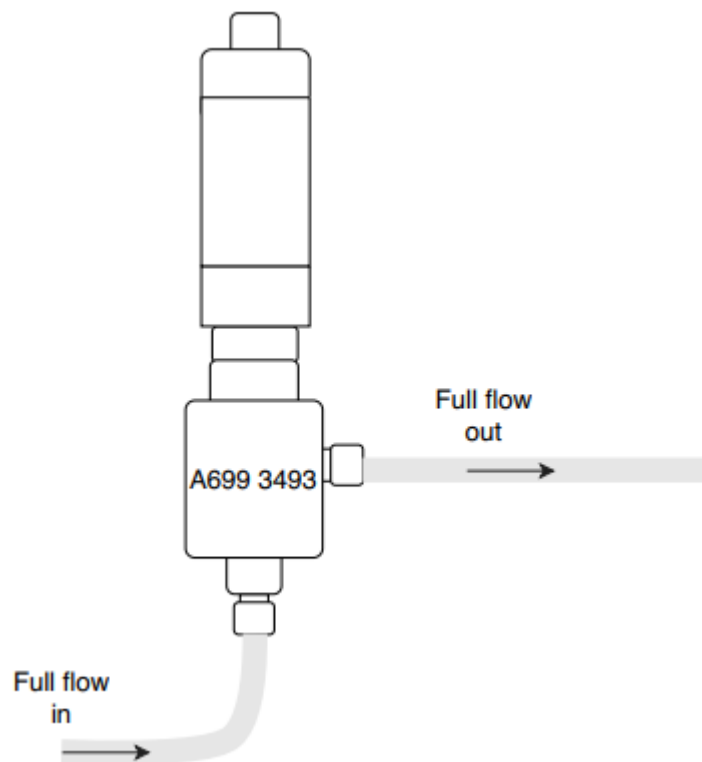

Method 2: By-pass installation

Note : In order to use the measurement chamber in a by-pass you must ensure a pressure difference between P1 and P2 as indicated in the picture below.

1. Connect the inlet of the chamber to your pipe system.
2. Connect the outlet of the chamber to your pipe system where the pressure is known to be lower than the inlet pressure.

Note : The pressure difference $P1 > P2$ is needed to create a by-pass flow through the chamber. If there is no pressure difference between P1 and P2, there will be no flow through the chamber and therefore the response time will be very slow or the device will not even respond at all to the dew point changes.

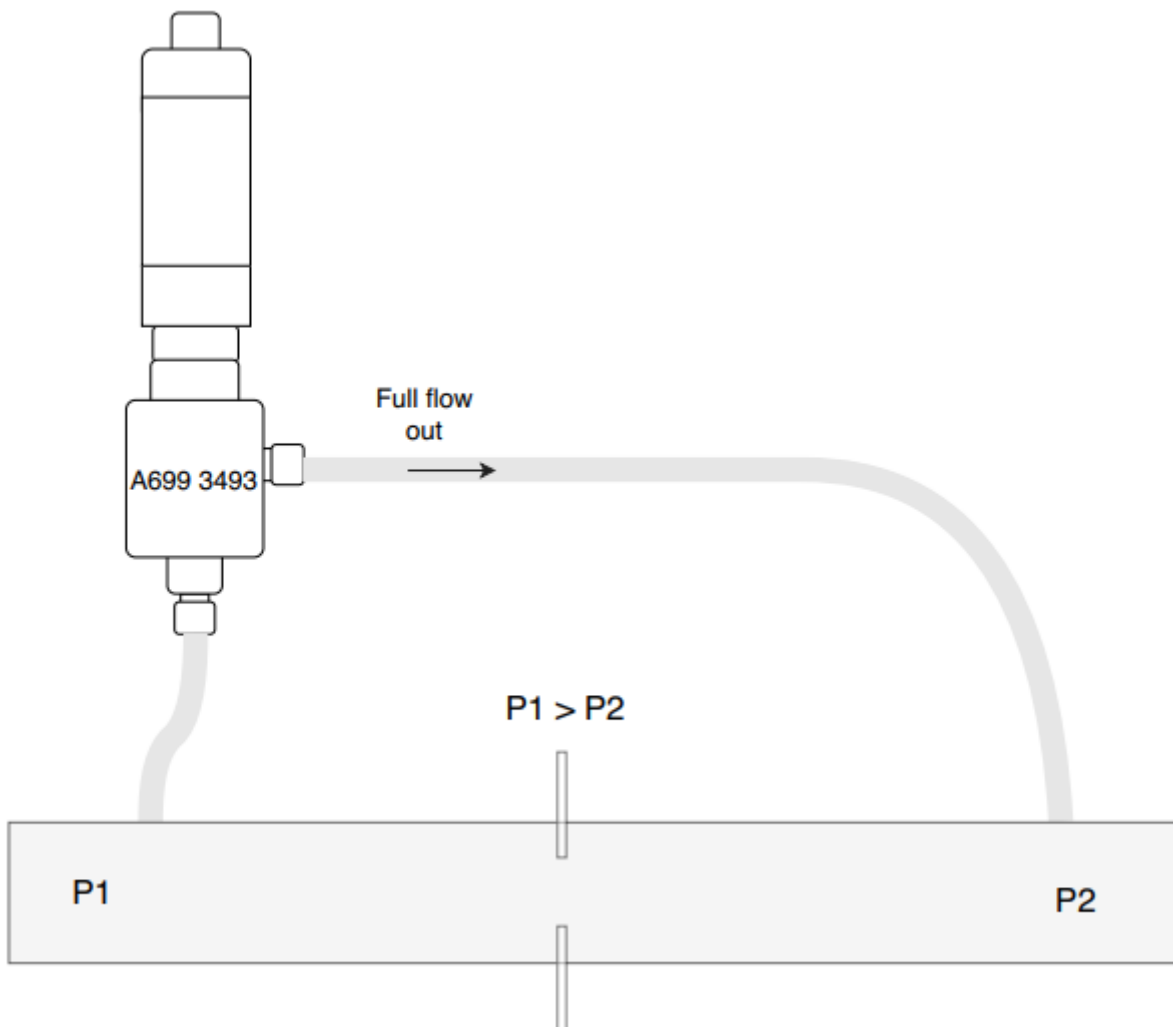

Installation without the measurement chamber

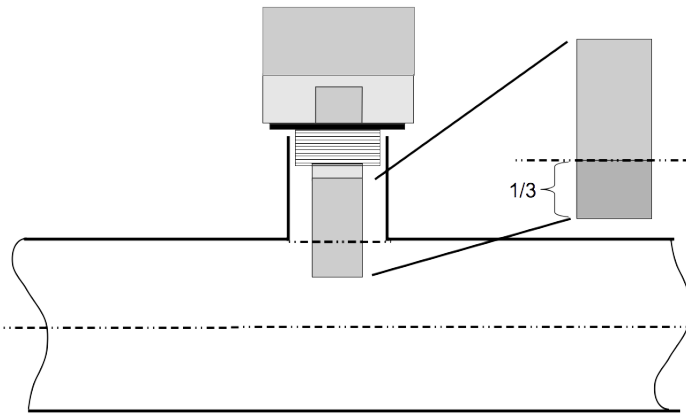

Full flow installation. The sensor is in the pipe.

- Install the device only if the system is pressure-less.
- Please check the size of the nozzle and make sure not less than 1/3 of the sensor tip is inside of the pipe.
- The inner thread must be G 1/2".

Remarks

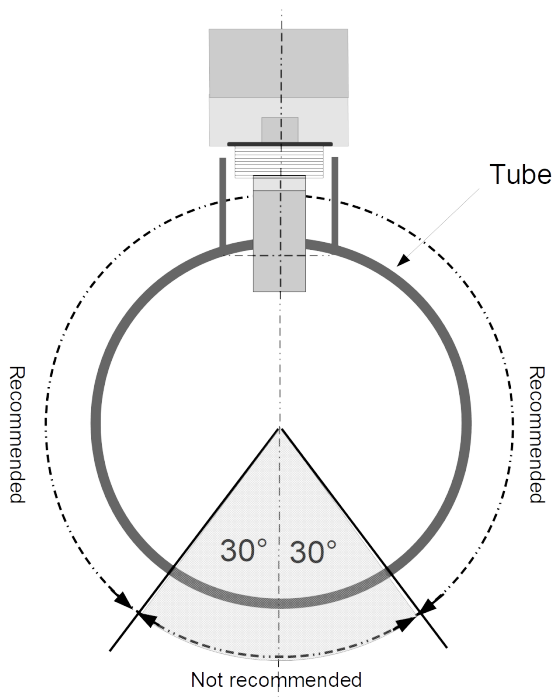

Please install the device only in the recommended area, as shown in the left picture.

The angle between the device and the centre vertical line of the tube must be greater than 30°.

An upside down installation is not permitted.

Removal of the Dew Point Transmitter

Unscrew the device off the measurement chamber or from the nozzle. Please make sure that the system is pressure-less before the Dew Point Transmitter is removed.

8.3 Electrical Connection

Connection pins of the M12 plug

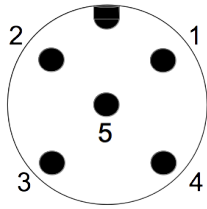

Connection pins
(View onto the connector)

Pin assignment of the M12 plug

Dew Point Transmitter versions: S699 1215 / S699 1211 / S699 1220

Output signal: 2-wire analog output and SDI

Pin 1	Pin 2	Pin 3	Pin 4	Pin 5
SDI	-V_B (Analog loop)	+V_B (Analog loop)	N/A	N/A
Brown	White	Blue	Black	Gray

Dew Point Transmitter versions: S699 2215 / S699 2211 / S699 2220

Output signal: 3-wire analog output and SDI

Pin 1	Pin 2	Pin 3	Pin 4	Pin 5
SDI	-V_B	+V_B	+I_a 4 ... 20 mA	NA
Brown	White	Blue	Black	Gray

Dew Point Transmitter versions: S699 3215 / S699 3211 / S699 3220 / S699 4215 / S699 4211/ S699 4220

Output signal: 3-wire analog output and Modbus/RTU

Pin 1	Pin 2	Pin 3	Pin 4	Pin 5
+I_a 4 ... 20 mA	-V_B	+V_B	D+ Modbus/RTU	D- Modbus/RTU
Brown	White	Blue	Black	Gray

Legend to pin assignment

SDI Digital signal (internal use)

-V_B Negative supply voltage

+V_B Positive supply voltage

+I_a Active 4 ... 20 mA signal

NA Not applicable

D+ Modbus/RTU data +

D- Modbus/RTU data -



ATTENTION!

Do not screw the M12 plug using force. Otherwise, it may damage the connecting pins.

8.4 Connection between S211/S215/S220 and Customer Equipment

This section provides figures to show how outputs supported by the S211/S215/S220 connect with the customer equipment.

In the following figures, the SUTO instrument indicates the S211/S215/S220.

2-wire analog output

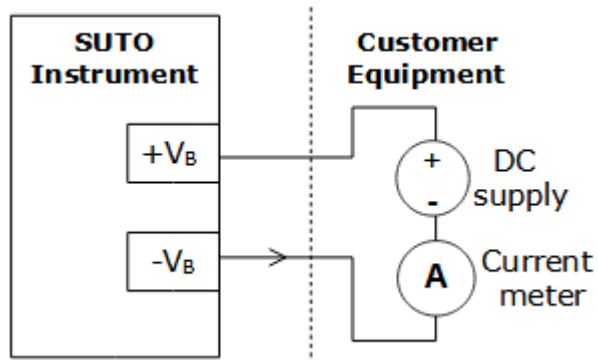

3-wire analog output

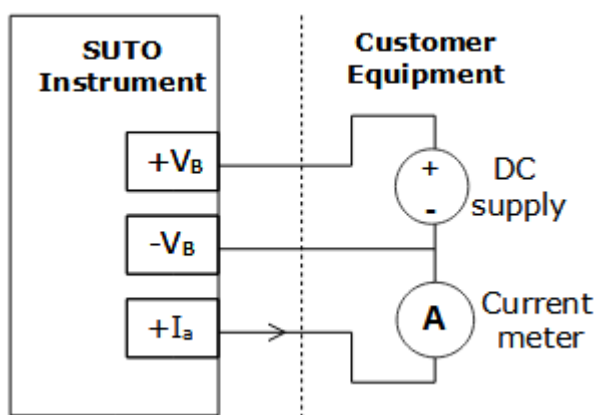

3-wire analog and Modbus/RTU outputs

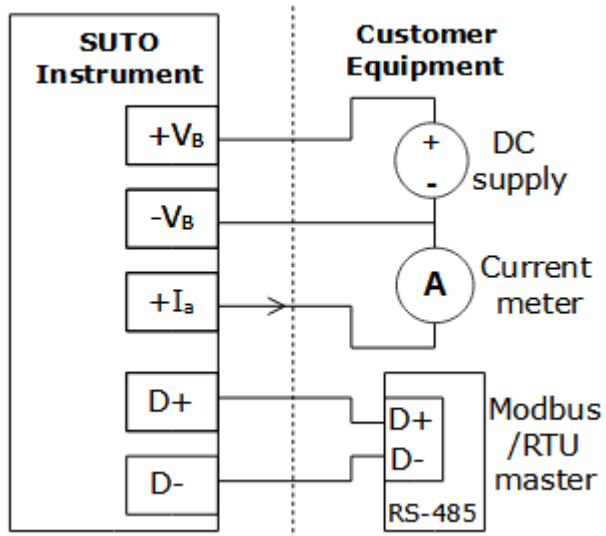

Modbus/RTU output

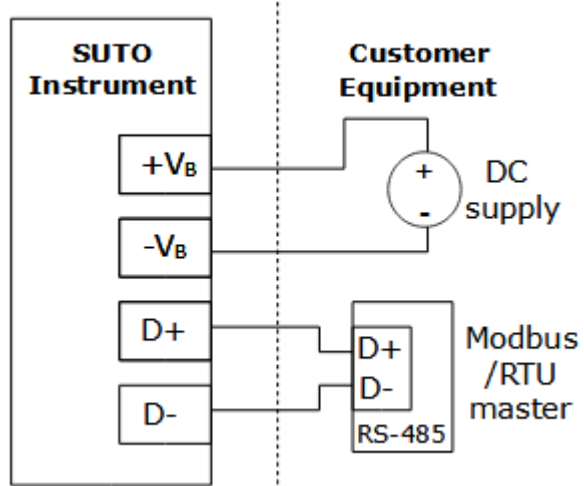

9 Signal Outputs

9.1 Analog Output

Depending on the model, the Dew Point Transmitter provides a 2-wire or 3-wire analog output. The analog output ranges 4 ... 20 mA.

- The 2-wire analog output is a current loop (loop-powered sensor).
- The 3-wire analog output is an active current output.

9.1.1 Scaling

The following table shows the standard scaling of the analog output.

Type	Scaling	
S211	4 mA	= -60°C Td
	20 mA	= +20°C Td
S215	4 mA	= -20°C Td
	20 mA	= +50°C Td
S220	4 mA	= -100°C Td
	20 mA	= +20°C Td

For other ranges, please contact the manufacturer. The analog output can be allocated to the temperature, dew point, and humidity.

9.2 Modbus/RTU Interface

The default settings of the Modbus interface are as follows.

Mode	RTU
Baud rate	19200
Device address	Last two digits of serial number
Framing / parity / stop bit	8 / N / 1
Response time	1 second
Response delay	0 ms
Inter-frame spacing	7 char

Response message that the device returns to the master:

- Function code: 03

The information for the byte order is shown in the table below:

Byte Order	Sequence				Data Type
	1st	2nd	3rd	4th	
1-0-3-2	Byte 1 (MMMMMMMM*)	Byte 0 (MMMMMMMM *)	Byte 3 (SEEEEEEE)	Byte 2 (EMMMMMMM *)	FLOAT
1-0-3-2	Byte 1	Byte 0 LSB	Byte 3 MSB	Byte 2	UINT32 INT32
1-0	Byte 1 MSB	Byte 0 LSB	---	---	UINT16 INT16
1-0	Byte 1 XXX *	Byte 0 DATA	---	---	UINT8 INT8

* S: Sign, E: Exponent, M: Mantissa, XXX: no value

Note: If your application needs other Modbus settings, please state it in the order. Modbus communication settings as well as other settings can be changed by the service App S4C-DP or through the windows based Service Software.

9.2.1 Holding Register Table for Modbus/RTU

Modbus Register Address	Channel description	Read/Write	Data Type	Data Length
2000	Group ID	R	INT16U	2-Byte
2001	Device ID	R	INT16U	2-Byte
2002	Serial number	R	INT32U	4-Byte
2004	FW/HW	R	INT16U	2-Byte
2005	Calibration date	R	DOUBLE	8-Byte
2009	Valid days from calibration date	R	INT16U	2-Byte
2010	Measuring Channel number	R	INT16U	2-Byte
2011	Device name	R	string	16-Byte
2100	Alternative humidity unit One byte on byte 0 of the holding register (see "unit" table on next page for details)	R/W	INT16U	2-Byte
2101	Static pressure (in bar(g))	R/W	FLOAT	4-Byte

2103	Atmospheric pressure (in hPa)	R/W	FLOAT	4-Byte
2200	Unit+Resolution+Data type of Dew point	R	INT16U	2-Byte
2201	Unit+Resolution+Data type of Alternative humidity	R	INT16U	2-Byte
2202	Unit+Resolution+Data type of Pressure	R	INT16U	2-Byte
2203	Unit+Resolution+Data type of Temperature	R	INT16U	2-Byte
2300	Status	R	INT16U	2-Byte
2301	Channel Value of Dew point	R	FLOAT	4-Byte
2303	Channel Value of Alternative humidity	R	FLOAT	4-Byte
2305	Channel Value of Pressure	R	FLOAT	4-Byte
2307	Channel Value of Temperature	R	FLOAT	4-Byte

- "Unit+Resolution+Data type" Channel

- First byte is unit.

1	°C	8	g/kg	36	MPa(g)
2	°F	9	g/m ³	38	bar(g)
3	% rH	30	ppm[v]	39	psi(g)
4	°C Td	31	°C Td atm.	54	g/m ³ atm.
5	°F Td	32	°F Td atm.	55	mg/m ³ atm.
7	mg/m ³	35	kPa(g)		

- Second byte:

Bit7	Bit6	Bit5	Bit4	Bit3	Bit2	Bit1	Bit0
Data type:				Resolution:			
0	float			0	0		
1	4-byte unsigned integer			1	0.0		

2	double	2	0.00
		3	0.000
		4	0.0000

- "Status" channel

The highest bit is used for indicating if any setting is changed by users. The rest bits are used for indicating if the measuring channels that follows the Status channel are working properly or not.

Bit	Description
15	0: Sensor settings have never been changed since last reading from the master. 1: Sensor settings have been changed since last reading from the master
0	0: The 1st measuring channel that follows the Status channel (addressed 2301) is working properly. 1: This measuring channel is not working properly.
1	0: The 2nd measuring channel that follows the Status channel (addressed 2303) is working properly. 1: This measuring channel is not working properly.
2	0: The 3rd measuring channel that follows the Status channel (addressed 2305) is working properly. 1: This measuring channel is not working properly.
3	0: The 4th measuring channel that follows the Status channel (addressed 2307) is working properly. 1: This measuring channel is not working properly.
4 ... 14	Not used

- Byte order for Multi-Byte data

2-byte	4-byte	8-byte
Byte1 Byte0	Byte1 Byte0 Byte3 Byte2	Byte1 Byte0 Byte3 Byte2 Byte5 Byte4 Byte7 Byte6

9.2.2 Connect Modbus/RTU Devices to a Master

Sensors and devices with a Modbus/RTU output can be connected to a Modbus master device. This master can be either SUTO displays and gateways or any third-party Modbus/RTU master.

See below specifications of the Modbus/RTU connections.

9.2.2.1 Modbus/RTU Cable Length

A Modbus/RTU bus line has limitations which shall not be exceeded, otherwise the communication might not be stable.

- The maximum total bus length must not exceed 1200 m.
- The stub length to each node must not exceed 30 cm.

See the picture below for details.

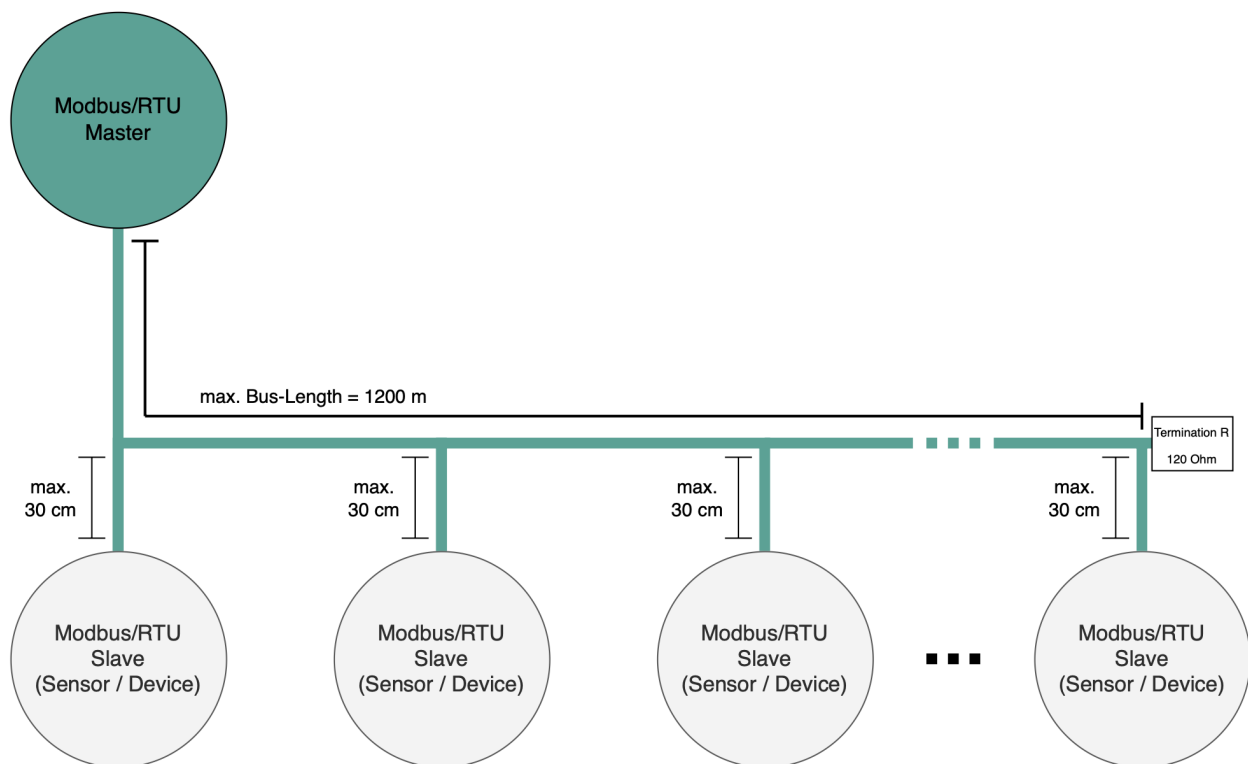

9.2.2.2 Modbus/RTU Wiring and Cable Type

To ensure a stable communication a twisted-pair bus cable must be chosen to set up the Modbus/RTU communication.

- Bus-cable specifications must follow the EIA485 Standard, must be twisted pair and shielded, for example 2 x 2 x 0.22 mm², Li-2YCY (A553 0123).

- The shield must be connected at one end to the master GND connection.
- At the end of the bus, a 120 Ohm resistor should be placed a termination resistor.

See the below picture for details.

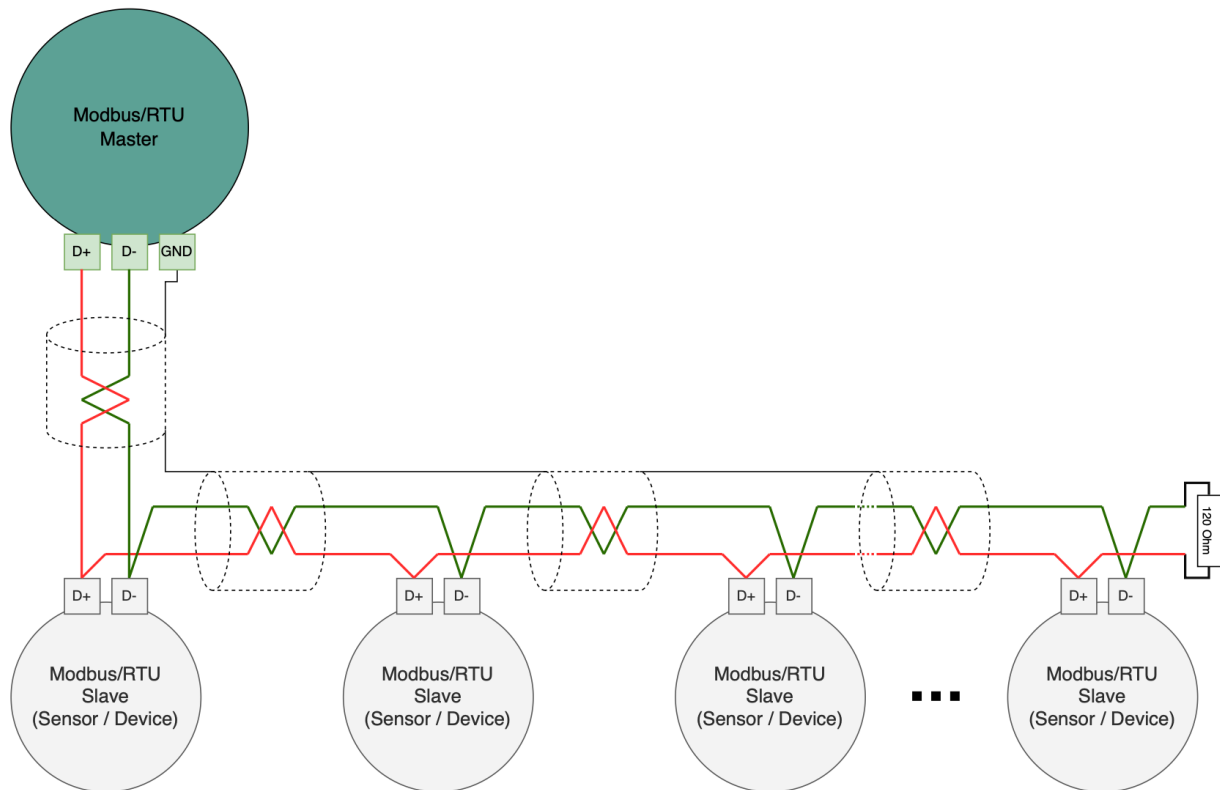

9.2.2.3 Daisy-Chain using RS-485 Splitter

SUTO devices with M12 connectors can be easily connected in a Modbus/RTU daisy-chain using a M12 RS-485 splitter (A554 3310). Furthermore this allows to easily place the M12 termination resistor (C219 0055) at the last splitter in the bus-chain.

See below example for reference.

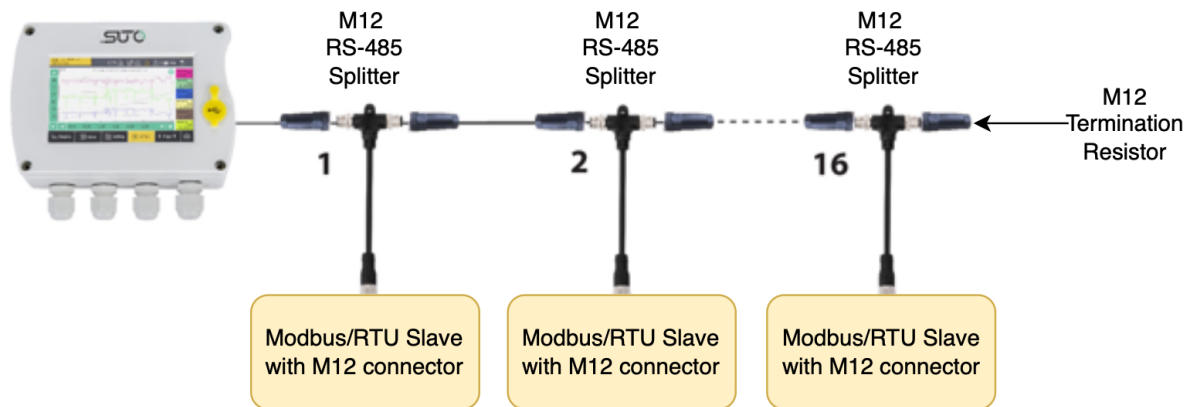

Connect Modbus/RTU slaves with M12 connectors to a daisy-chain using M12 RS-485 splitters.

The M12 RS-485 splitter (A554 3310) comes with two M12 connectors to easily wire the chain.

9.2.2.4 Topology of Modbus/RTU Daisy-Chain

The recommended bus topology is to connect devices as a daisy-chain. Other connection topologies are not recommended and should be avoided.

Make sure that at the end of the bus line, the termination resistor of 120 Ohm is placed to avoid interferences.

Recommended connection of Modbus/RTU slaves in a daisy-chain topology.

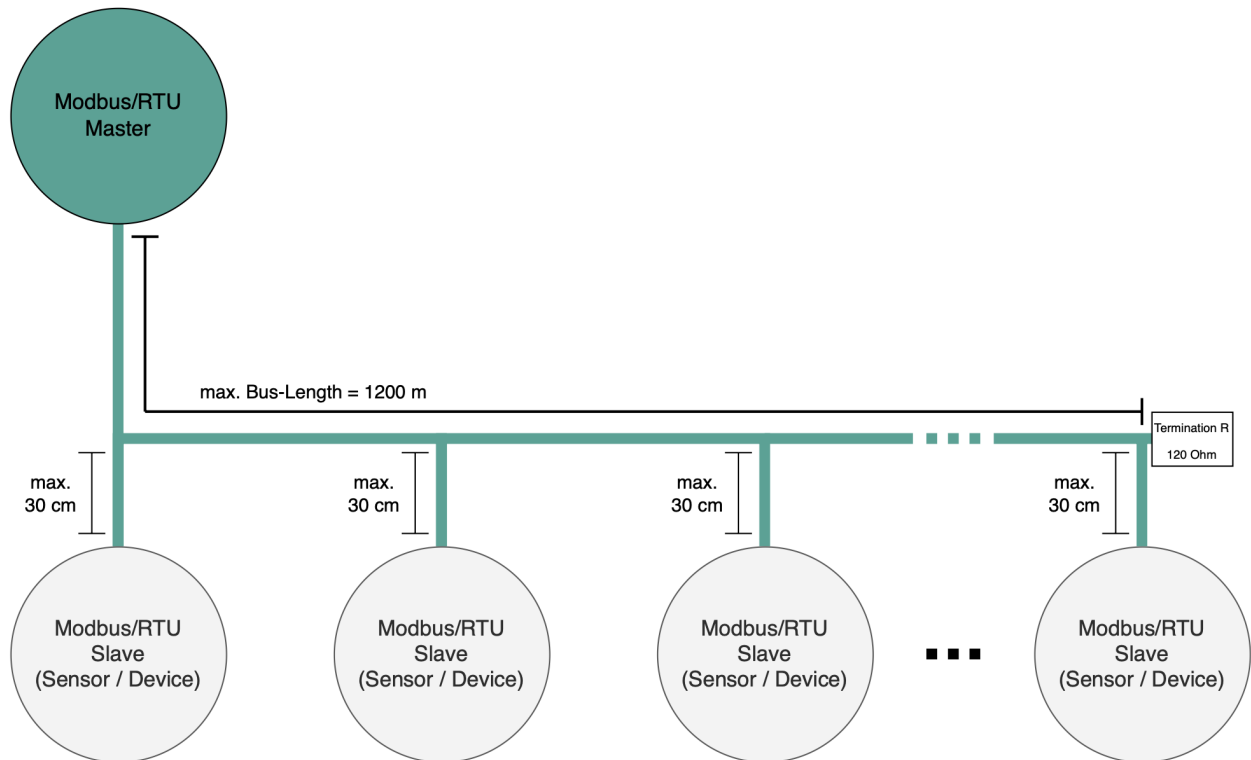

Avoid a connection of slaves to the master in ring or star topology.

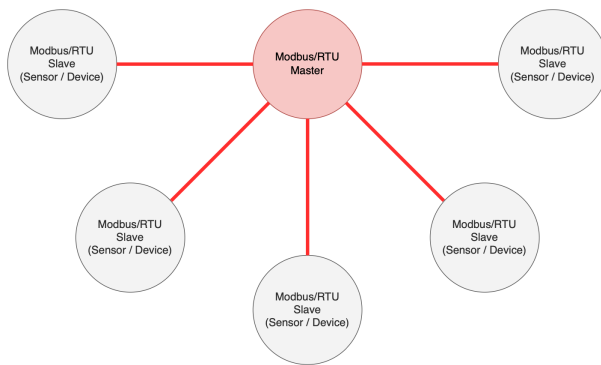

Avoid a star topology

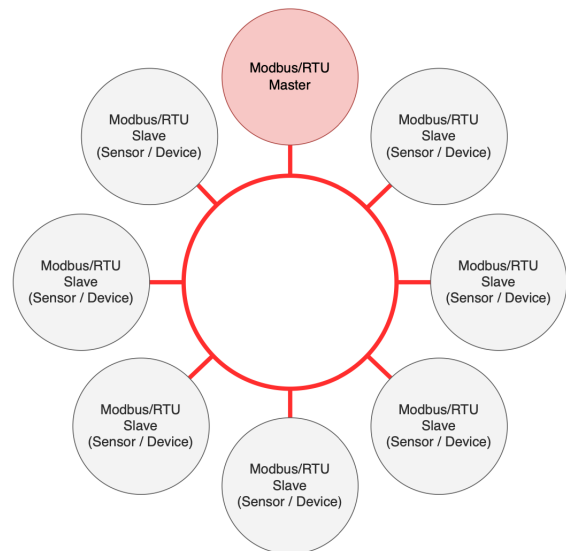

Avoid a ring topology

10 Optional Accessories

10.1 Measuring Chambers

There are different types of measuring chambers for example Measuring chamber with quick connector, by-pass chamber with in and out connection, measuring chamber for dryer installation, or high pressure chamber.

For more information, please contact your distributor or the manufacturer.

10.2 Service Kit

The service kit is used to connect the device with a PC. Through the service software that is installed on the PC, device parameters such as analog output scaling, alarm values, units can be easily changed.

The diagram below shows the connection when using the optional service kit. Please make sure that either the Dew Point Transmitter or the service kit is connected to the power supply because the USB port on the PC cannot supply enough power for both of them.

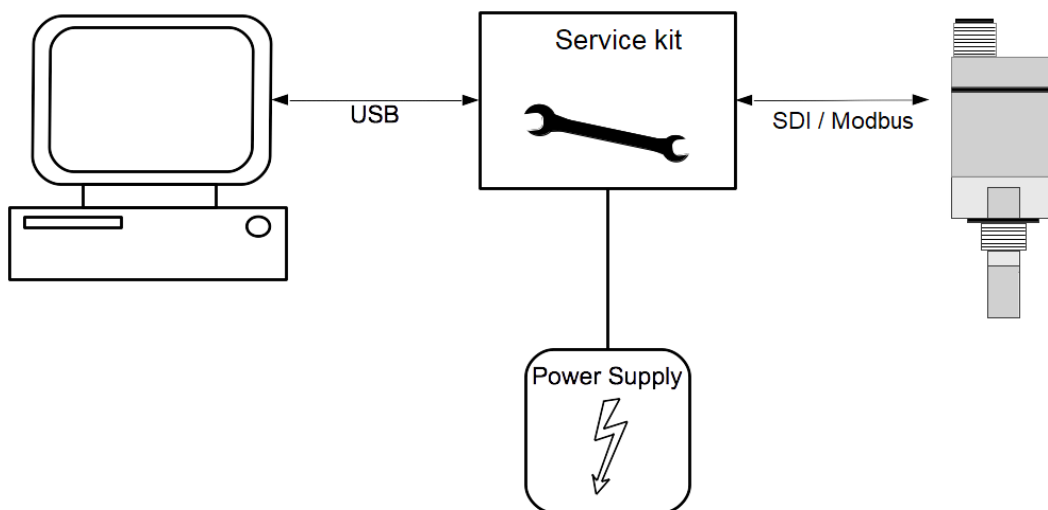

11 Calibration

The instrument is calibrated ex work. The exact calibration date is printed on the certificate that is supplied together with the instrument . The accuracy of the instrument is regulated by the on-site conditions, and parameters such as oil, high humidity, and other impurities can affect the calibration and furthermore the accuracy. Therefore we recommend you calibrate the instrument at least once per year. The calibration is excluded from the instrument warranty. Please contact the

manufacturer for details.

12 Maintenance

Please observe from time to time the sinter cap. If it appears to be dirty, it is recommended to replace it for this please contact the manufacturer.



ATTENTION!

Contaminated filters can lead to longer response time and to wrong measurements.

13 Disposal or Waste



Electronic devices are recyclable material and do not belong in the household waste.

The device, the accessories and its packings must be disposed according to your local statutory requirements.

The dispose can also be carried by the manufacturer of the product, for this please contact the manufacturer.

SUTO iTEC GmbH

Grißheimer Weg 21
D-79423 Heitersheim
Germany

Tel: +49 (0) 7634 50488 00
Email: sales@suto-itec.com
Website: www.suto-itec.com

SUTO iTEC (ASIA) Co., Ltd.

Room 10, 6/F, Block B, Cambridge Plaza
188 San Wan Road, Sheung Shui, N.T.
Hong Kong

Tel: +852 2328 9782
Email: sales.asia@suto-itec.com
Website: www.suto-itec.com

SUTO iTEC Inc.

5460 33rd St SE
Grand Rapids, MI 49512
USA

Tel: +1 (616) 800-7886
Email: sales.us@suto-itec.com
Website: www.suto-itec.com

All rights reserved ©

Modifications and errors reserved

S211-S215-S220_im_en_2022-5
