



English

Instruction and operation manual

S435

Vortex Flow Meter for Steam (Inline)



Dear Customer,

Thank you for choosing our product.

Please read this manual in full before you start up the device and carefully observe instructions stated in this manual. The manufacturer cannot be held liable for any damage that occurs as a result of non-observance or non-compliance with this manual.

Should the device be tampered with in any manner other than a procedure that is described and specified in the manual, the warranty is void and the manufacturer is exempt from liability.

The device is designed exclusively for the described application.

SUTO offers no guarantee for the suitability for any other purpose. SUTO is also not liable for consequential damage resulting from the delivery, capability or use of this device.

Table of Contents

1	Safety Instructions.....	5
2	Registered Trademarks.....	7
3	Application.....	8
4	Technical Data	8
4.1	General	8
4.2	Electrical Data General.....	8
5	Dimensional Drawing.....	9
6	Installation	10
6.1	Installation Requirements.....	10
6.2	Installation Instructions.....	12
6.2.1	Error between the Inner Diameters of Pipes.....	12
6.2.2	Straight Pipe Requirements.....	12
6.2.3	Wafer Type of Vortex Flow Meter Installation	14
6.2.4	Flange and Bolt.....	15
6.3	Electrical Connection.....	15
6.3.1	Requirements on Cable.....	15
6.3.2	Terminal Connection	16
6.4	Power Supply Connection.....	17
6.5	Frequency Output.....	17
6.6	RS-485 Communication	18
7	Parameter Setting	19
7.1	Keypad and Display.....	19
7.2	Parameter Setting Function and Operation.....	21
7.3	Operation Menu.....	21
7.4	Quick Setup Menu List	22
7.5	Parameter Settings Instruction.....	23
7.5.1	Nominal Size.....	23
7.5.2	Flow Unit.....	23
7.5.3	LowFlow Cutoff.....	23
7.5.4	Flow Range.....	23
7.5.5	Language.....	23
7.5.6	Output Mode.....	23
7.5.7	Output Freq.....	23
7.5.8	CommAddress	24
7.5.9	Band Rate.....	24
7.5.10	CompensMode	24
7.5.11	CompSetTemp.....	25
7.5.12	CompSetPress.....	25
7.5.13	RTD Sel.....	25
7.5.14	PressMax.....	25
7.5.15	VoltageMin/ VoltageMax/ Sensor Type.....	25

7.5.16 AtmSet.....	25
7.5.17 Press Unit.....	25
7.5.18 Press Cut Off.....	25
7.6 Instrument On-site Debugging.....	26
7.7 Total Reset.....	26
7.8 Communication Mode Selection.....	26
7.9 Temperature and Pressure Compensation Function.....	26
8 Troubleshooting	28
9 Disposal or Waste.....	29
10 Appendix A: Flow Measurement Range.....	30
11 Appendix B: Modbus Communications.....	31
11.1 Introduction.....	31
11.2 Modbus Networking and Wiring.....	31
11.3 Modbus Messages in RTU Framing.....	31
11.3.1 Master Order Frame Structure.....	32
11.3.2 Slave response frame structure.....	32
11.4 Function Codes.....	33
11.5 Definition of addresses.....	33
11.6 Modbus Registers.....	33
11.6.1 S435 Data Type.....	33
11.6.2 Modbus Register Addresses.....	34
11.6.3 Description of Data.....	36
11.7 Communication Data Analysis.....	37
11.7.1 Read Instantaneous Flow.....	37
11.7.2 Read Cumulative Flow.....	38

1 Safety Instructions

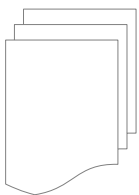

Please check if this instruction manual matches with the product type.

Please observe all notes and instructions indicated in this manual. This manual contains essential information that must be observed before and during installation, operation and maintenance. Therefore this manual must be read carefully by the technician as well as by the responsible user or qualified personnel.

This instruction manual must be available at the operation site of the product at any time. In case of any obscurities or questions regarding this manual or the product, please contact the manufacturer.



WARNING!

Compressed air!

Any contact with quickly escaping air or bursting parts of the compressed air system can lead to serious injuries or even death!

- Do not exceed the maximum permitted pressure range (see sensors label).
- Use only pressure-tight installation material.
- Prevent persons from being hit by escaping air or bursting parts of the instrument.
- The system must be pressureless during maintenance work.



WARNING!

Voltage used for supply!

Any contact with energized parts of the device may lead to an electrical shock which can lead to serious injuries or even death!

- Consider all regulations for electrical installations.
- The system must be disconnected from any power supply during maintenance.
- Any electrical work on system is allowed only by authorized qualified personal.

**ATTENTION!****Permitted operating parameters!**

Observe the permitted operating parameters. Any operation beyond these parameters can lead to malfunctions and may lead to damage on the product or the system.

- Do not exceed the permitted operating parameters.
- Make sure that the product is operated under its permitted conditions.
- Store and operate the product at the permitted temperature and pressure.
- The product should be maintained and calibrated frequently, at least annually.

General safety instructions

- It is not allowed to use the product in explosive areas.
- Please observe the national regulations before and during installation and operation.

Notes

- It is not allowed to disassemble the product.
- Always use spanners to mount the product properly.

**ATTENTION!****Measurement values can be affected by malfunction!**

The product must be installed properly and maintained frequently. Otherwise it may lead to wrong measurement values, which can lead to wrong results.

- Always observe the direction of the flow when installing the device. The direction is indicated on the housing.
- Do not exceed the maximum operation temperature at the sensors tip.
- Avoid condensation on the sensor element because it will affect accuracy enormously.

Storage and transportation

- It is recommended to use the packaging that comes with the product for storage and transportation.
- Make sure that the storage temperature is between -10°C ... +65°C. The ideal temperature and humidity range is 25°C and 65%.
- Avoid direct UV and solar radiation during storage.
- The storage humidity must be between 5% ... 90% with no condensation.

2 Registered Trademarks

SUTO®	Registered trademark of SUTO iTEC
MODBUS®	Registered trademark of the Modbus Organization, Hopkinton, USA
HART®	Registered trademark of the HART Communication Foundation, Austin, USA
Android™, Google Play	Trademarks of Google LLC

3 Application

The S435 Vortex Flow Meter for Steam operates based on the Karman Vortices principle, and is used to measure flow rates in saturated steam applications.

4 Technical Data

4.1 General

Measured fluid	Steam Gas
Nominal diameter (mm)	DN40 ... DN300 wafer type
Medium temperature	-40°C ... +250°C
Ambient temperature	-10°C ... +60°C
Accuracy	±1.5% of reading
Repeatability	0.5%
Display	Instant flow rate / Total flow rate / Frequency / Percentage of flow range
Signal output	Pulse output / Modbus
Protection level	IP65
Electrical connection	1/2" -14NPT
Installing type	Wafer type
Wetted parts material	304 stainless steel
Process control material	Carbon steel /304/316/316L (Flange/Wafer)
Detector probe	316 Stainless steel
Connecting rod	304 Stainless steel
Radiator	Aluminium alloy
Range ratio	10:1

4.2 Electrical Data General

Power supply	24 VDC
--------------	--------

5 Dimensional Drawing

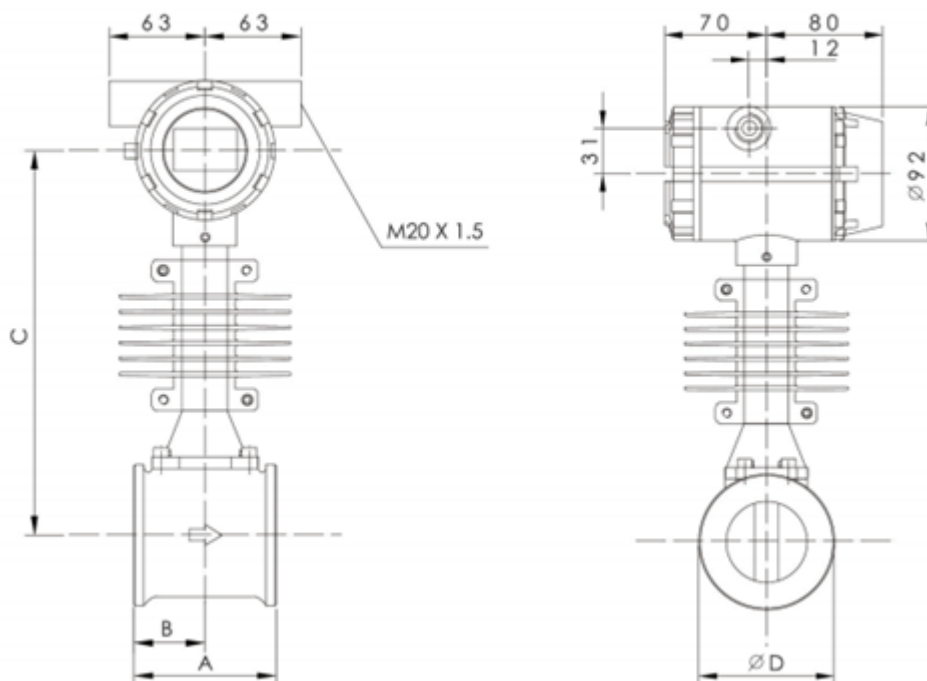

Figure 1 Outline dimensional drawing of Vortex Flow Meter for Steam

DN	Vortex Flow Meter Dimension Rated Pressure 1.6 MPa Unit: mm			
	A	B	C	ΦD
40	100	50	256	75
50	110	55	256	87
65	110	55	262	109
80	110	55	267	120
100	120	60	271	149
125	133	73	291	175
150	160	90	304	203
200	185	115	331	259
250	210	140	357	312
300	240	165	383	363

6 Installation

Make sure that all components listed below are included in your package.

Qty	Description	Item No.
1	Vortex Flow Meter for Steam	S695 435X* *X denotes the last digit, which varies with pipe sizes
1	Companion flange with the bolt and gasket included	NA
1	Calibration certificate	NA
1	Instruction manual	NA

6.1 Installation Requirements

Ensure the following when installing the flow meter:

- The flow direction should match the arrow direction on the flow meter.
- The flange bolts have been fastened to the max torque rating.
- Mechanical stress (twist and bent) should not exist when installation. Mating flanges should keep axial symmetrical and parallel, and proper gaskets should be used.
- Gaskets should not be extended to the flow area, otherwise whirlpool generated and affecting accuracy of the flow meter.
- Any force and moment from the pipe should not affect the flow meter.
- The display of the flow meter should face the users.
- Protecting plug of the cable entries are only allowed to be removed when wiring.
- Remotely installed sensors should be mounted on places that is almost vibration-free.
- Converter of the flow meter should be free from direct sunshine. (Shade is required)

Observe the following rules when choosing the installation places:

- No negative pressure in measuring tube.
- Avoid being installed near motor, transformer, and other strong

current equipment, to avoid jammer.

- Avoid being installed near strong corrosion gas.
- Avoid being installed in separated place, when measuring mixed fluid.
- Avoid being under direct sunlight, ambient temperature should be $-25^{\circ}\text{C} \dots +65^{\circ}\text{C}$.
- Choose places without or with less vibration. If too much vibration, install fixed support before and after the pipe.
- Relative humidity is 5% ... 90%.
- Avoid direct rain and soaked places.
- Prevent liquid retention.
- The flow meter should be mounted on a vertical pipe to prevent accumulation of fluid.
- When the flow meter is installed horizontally, raise the pipe section installed with the flow meter.

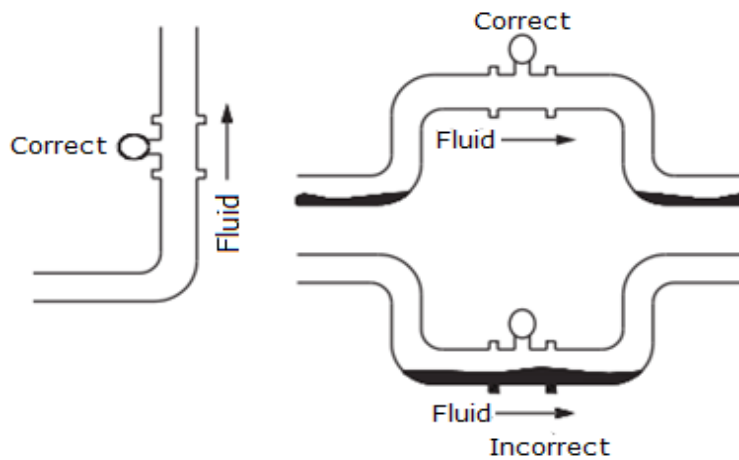



6.2 Installation Instructions

6.2.1 Error between the Inner Diameters of Pipes

- The inner diameter of the pipe should be as close as possible to the inner diameter of the meter, and there should be no obvious deviation.
- Ensure that the inner wall of the pipe on both sides of the flow meter is smooth and free of surfacing.

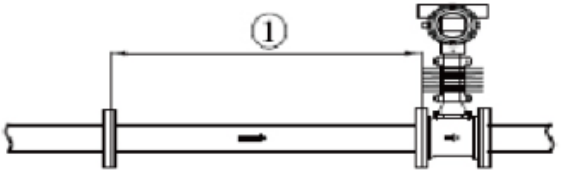
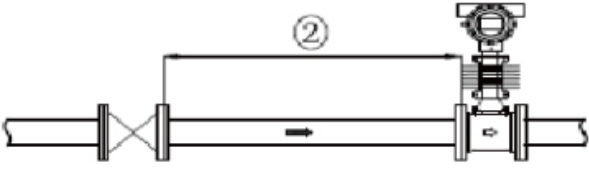
6.2.2 Straight Pipe Requirements

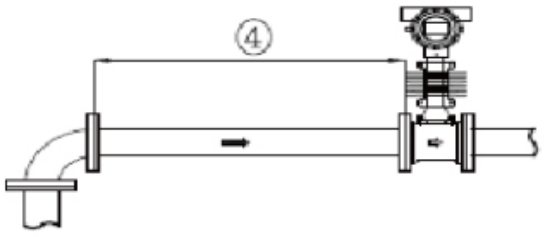
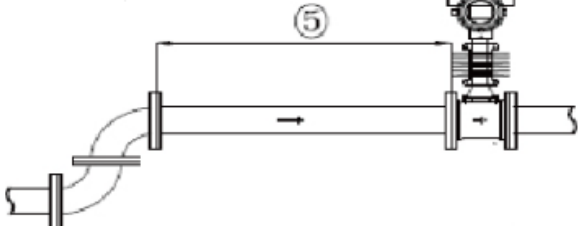
Description	Illustration
1. Flow condition at the entrance shouldn't be interfered $\geq 10D$	
2. Behind the valve $\geq 35D$	
3. Reducing pipe $\geq 15D$	
4. One 90° bent pipe $\geq 20D$	
5. Two 90° bent pipes on one flat surface $\geq 30D$	

<p>6. Two 90° bent pipes on different flat surfaces ≥ 40 DN</p>	
<p>1. Downstream Straight Pipe $\geq 5D$</p>	
<p>2. Measuring point away from vortex flow meter $\geq (4-6)D$</p>	
<p>3. Advice: The meter is installed upstream of the valve</p>	
<p>4. Not advice: the meter is mounted directly behind the valve</p>	
<p>5. Maximum height of insulation layer</p>	

- Cleaning the pipeline:
1. For newly installed or repaired pipes, flush out rust, scale, residue and sludge from the pipes before operation.
 2. When flushing, water flows through the bypass line to avoid damage to the flow meter.
 3. If there is no bypass, temporarily install a short pipe to replace the flow meter.

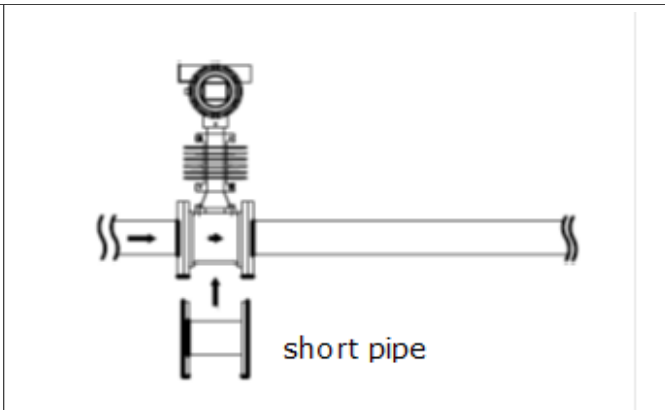

6.2.3 Wafer Type of Vortex Flow Meter Installation

Wafer	Description
<p>Note:</p> <ul style="list-style-type: none"> • The inner diameter of the gasket must be larger than the inner diameter of the pipe so that it does not interfere with the flow inside the tube. • When the flow meter is installed vertically in an open position, the wiring port should face downwards, otherwise it will leak rain when it rains. 	<p>Positioning and installation of the wafer type flow meter</p> <p>The diagram shows a cross-section of a wafer type vortex flow meter installed in a pipe. The flow meter is positioned vertically. A graphite gasket is used to seal the meter to the pipe. An FM seal flange is used for alignment. Installation studs, nuts, and gaskets are used to secure the meter. An arrow indicates the flow direction through the pipe.</p>

6.2.4 Flange and Bolt

Companion flange and bolts are used to install vortex flow meters between the two flanges. The following table lists the recommended minimum bolt lengths for wafer type flow meter and flanges of different grades.

Recommended minimum bolt lengths for various flange grades are listed below.

Nominal diameter	PN16	PN25	PN40
DN40	220	220	240
DN50	220	220	240
DN65	220	220	240
DN80	220	220	240
DN100	240	240	270
DN125	240	240	270
DN150	270	270	300
DN200	300	300	350
DN250	350	350	370
DN300	370	370	400

6.3 Electrical Connection

6.3.1 Requirements on Cable

Cable	Illustration
According to requirement of the protection level, we advise that: Cable does not knot at the entrance, Use drip bend (Cable U-bend to avoid water intake).	

6.3.2 Terminal Connection

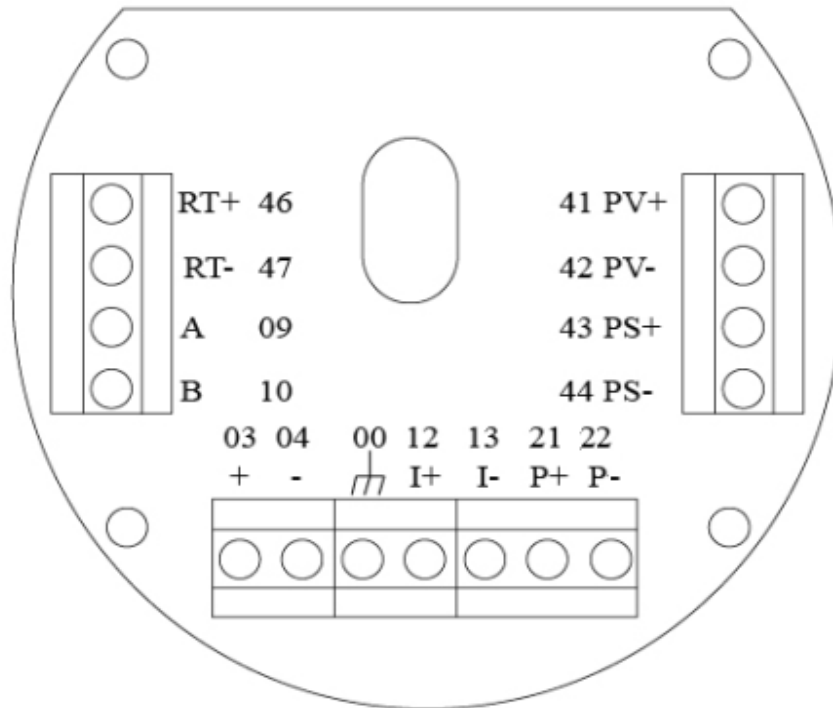

Terminal connection diagram

The definition of terminals and their marks is given as below:

Terminals	Terminal code	Description
+	03	DC 24 V+
-	-04	DC 24 V-
	00	GND
I+	12	Output Current anode
I-	13	Output Current cathode
P+	21	pulse output
P-	22	pulse common
B	10	RS-485
A	09	RS-485
RT+	46	Resistance Temperature Detector Signal positive
RT-	47	Resistance Temperature Detector Signal negative
PV+	41	Pressure sensors Power supply positive pole
PV-	42	Pressure sensors power supply negative pole

Terminals	Terminal code	Description
PS+	43	Pressure sensors Signal positive
PS-	44	Pressure sensors Signal negative

Notes:

- The frequency output is active output.
- The thermal resistance is two-wire; the pressure equipment supports: pressure transmitter and pressure sensor.

6.4 Power Supply Connection

The vortex flow meter can use DC power supply 18 ... 30 VDC. Three-wire Vortex flow meter (with compensation) 24 VDC power supply wiring is as following.

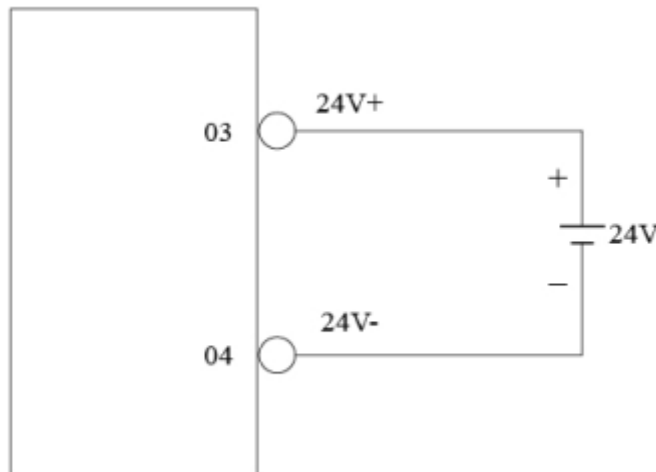
**6.5 Frequency Output**

The upper limit of the frequency output range is adjustable from 0...5000 Hz, and the frequency output corresponds to the flow percentage. User can choose 0...5000 Hz, also can select a lower frequency, for example 0...1000 Hz or 0...2000 Hz, etc.

POUT are transistor open collector output.

Frequency output

The frequency output is active digital output direct connection.

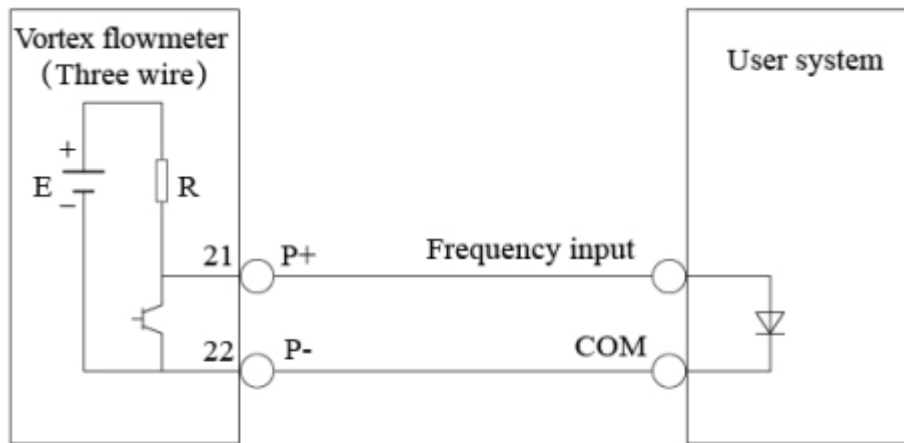

Parallel connection method digital output connection

6.6 RS-485 Communication

The three-wire vortex flow meter adopts RS-485 communication mode. In order to eliminate signal reflections in the communication cable, Parallel 120Ω termination resistor to the flow meter terminal A, B line at the end of the RS-485 which is close to the flow meter.

The wiring can refer to the following:

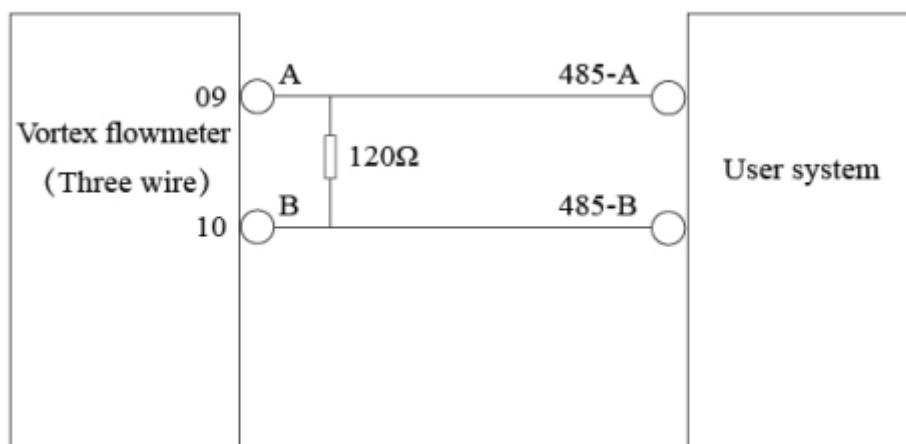

RS485 Communication wiring

7 Parameter Setting



7.1 Keypad and Display

Display interface: Enter the display interface when powered.

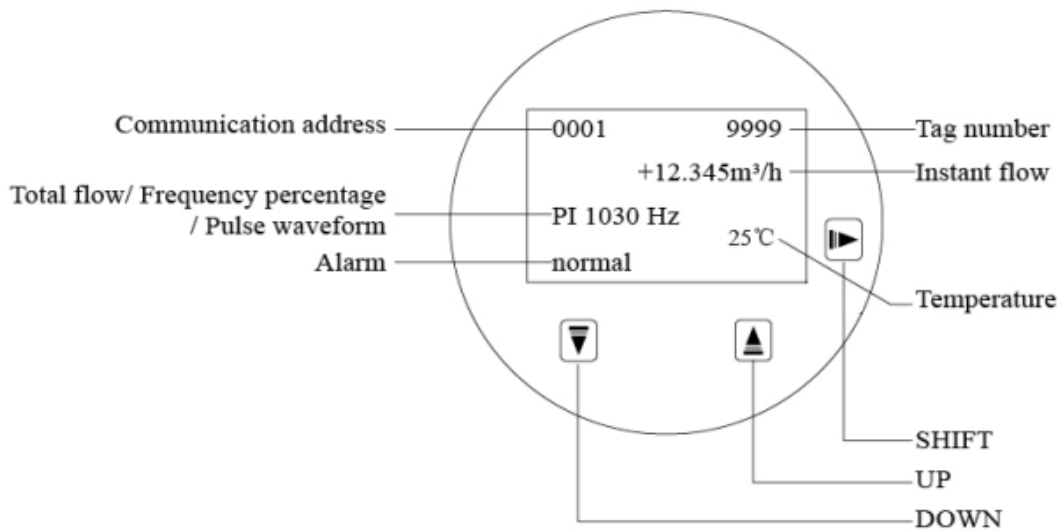

Setup menu: Press SHIFT key on the display interface, the converter will display a login page and password is required. Input proper password, and the system enters into the setup mode. There are three keys on the keypad. They can be used to enter the parameter setting mode and change the meter's configuration.





Single button function:

	<p>Shift: Under the setting parameter menu, this button is used as a combination button. Press this button when entering a number to select the set digit, Shift right in the screen of number.</p>
	<p>Up: In parameter setting status, press this key, screen can display the upper content circularly, and press this key can increase the numbers.</p>
	<p>Down: In parameter setting status, press this key, screen can display the next content circularly, and press this key can decrease the numbers.</p>

Combination button function:

Press simultaneously   ESC

Press simultaneously   ENTER

On the main display interface, Press  repeatedly, the third line can show the following content: Total flow, signal frequency, output frequency, flow percentage, pulse waveform.

BT	0	Displays Bluetooth information.
T	00000 m ³	Displays the total flow rate.
FP	0.0 %	Displays the percentage of instantaneous flow rate.
PO	00000 Hz	Displays the output frequency.
PI	00000 Hz	Displays the sensor signal frequency.

Press Key Operation Instructions

1. After power on, press "ENTER", the screen will show parameter setting password (000000).
2. Enter into the password code.
3. Press "ENTER", it will enter into the main menu interface;
4. Press "UP" or "DOWN", choose the menu that need to setup, press "ENTER", and press "UP" or "DOWN", choose the required parameter values, press "ENTER" to exit the menu.
5. Press "UP" or "DOWN", choose the next menu that need to setup. After the setup, press "ENTER" for three seconds to exit the parameter setting. And press "SHIFT+UP", return to the previous menus.

7.2 Parameter Setting Function and Operation

The password of the instrument designed is as follows: three levels of passwords for users. They are the basic password, the advanced password, and the total flow clear password. In the main interface, press "Enter" to enter the password setting interface. Enter a different password to get the appropriate permissions to set different parameters. Basic password: 000321. If you need other passwords, contact the manufacturer's technicians.

Basic password (level 1): basic parameters, output parameters, advanced settings, information query.

Total flow clear password: Clear the total flow to zero.

Note: After the parameters setting, the flow meter should be powered on again to ensure the meter works normally.

7.3 Operation Menu

Menu	Setting	Description
Basic setup (No password)	Tag	0 ~ 9999
	Fluid range	0 ~ 10000
	Flow Unit	m ³ /h, Nm ³ /h, kg/h, t/h
	Language	Chinese, English
	Back Light	Always on/not on/15s/30s/1 ~ 5min
Output setup (No password)	Output Mode	Current/ Freq/ Pulse
	CommAddress	0 ~ 247 (RS-485 Communication) 0 ~ 15 (HART Communication)
	Band Rate	1200 ~ 115200 bps
Advanced settings (Password: 000321)	Fluid Dens.	0.0 ~ 9999.0 kg/m ³
	Sensor Size	15 ~ 300mm
	Meter Fact	0.0000 ~ 59999
	Compr. Factor	1.000 ~ 60.000 Note: This parameter is not displayed when applied to liquids or using temperature and pressure compensation.
	Filt Time	1 ~ 60s
	Flow Cutoff	0 ~ 10000
	Total Reset	Clear the cumulative flow
	Total Value	0 ~ 10000000000
	Analog Test	0.0000 ~ 24.000 mA
	PO Test	0.0000 ~ 5000.0 Hz

Menu	Setting	Description
	User Pwd.	Set user password
Information query (No password)	N/A	Display the sensor information

7.4 Quick Setup Menu List

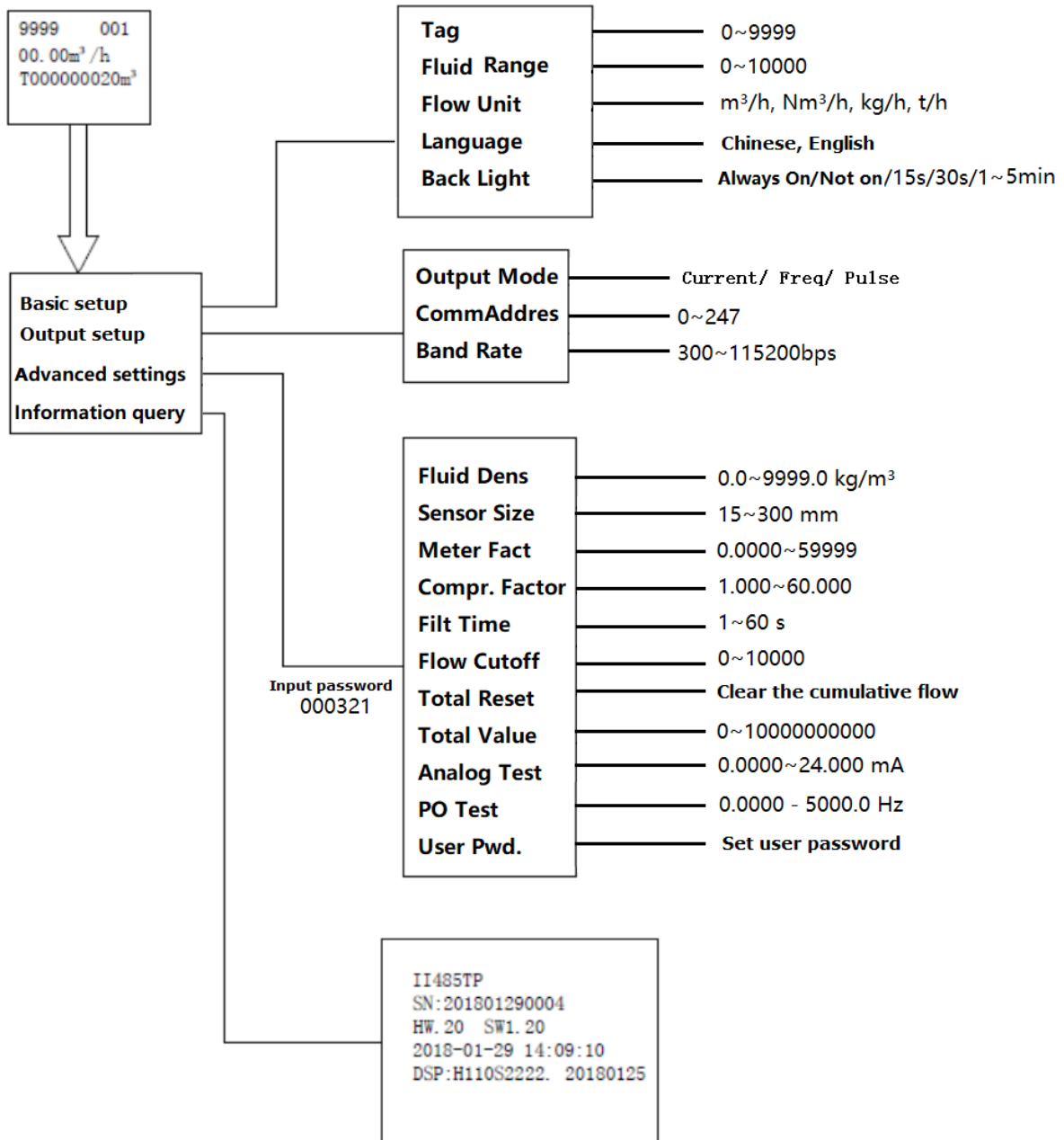

7.5 Parameter Settings Instruction

7.5.1 Nominal Size

The flow meter is available in 9 sizes, that's 50 mm, 65 mm, 80 mm, 100 mm, 125 mm, 150 mm, 200 mm, 250 mm, 300 mm. The diameter of the flow meter after delivery of the factory is fixed, and it is not recommended to modify it at will.

7.5.2 Flow Unit

The flow unit is divided into four types: m^3/h , Nm^3/h , kg/h , and t/h . M^3/h and Nm^3/h are volumetric flows; kg/h and t/h are mass flow rates. The instantaneous flow unit and the cumulative flow unit are the same.

7.5.3 LowFlow Cutoff

Cut off the flow according to the flow range, and the unit is the same as flow unit. When the flow rate is lower than the small flow cutoff value, the flow rate can stably indicate zero.

7.5.4 Flow Range

To make the current output correspond to flow range, you need to set the upper limit of the flow range, then the whole flow range is determined and corresponding to 4 ... 20 mA.

7.5.5 Language

Two languages are available: Chinese and English.

7.5.6 Output Mode

There are 5 output modes: Current, frequency, pulse, current+ frequency, and current + pulse. The pulse is a direct pulse, and the current and frequency are output as a percentage.

7.5.7 Output Freq.

Output frequency setting, that is, the output frequency upper limit setting; the output frequency lower limit defaults to 0, no setting is required; The output frequency setting range is (0 ~ 5000) Hz (can be set). The frequency output corresponds to the percentage of flow.

7.5.8 CommAddress

When communication with HART, the address should be changed into non-zero and the address range is 01 ~ 247.

When communication with RS-485, the address should be changed into non-zero and the address range is 01 ~ 247.

7.5.9 Band Rate

There are 8 band rates for customer to choose, that is 1200, 2400, 4800, 9600, 19200, 38400, 57600, and 115200 bps.

This parameter is valid only for RS-485 communication.

7.5.10 CompensMode

This flow meter has 13 types of temperature and pressure compensation methods:

1. Density – No compensation
2. Gas_MTMP – Gas - Measure Temperature and Measure Pressure.
3. Gas_MTSP – Gas - Measure Temperature and Set Pressure.
4. Gas_STMP – Gas - Set Temperature and Measure Pressure.
5. Gas_STSP – Gas - Set Temperature and Set Pressure.
6. Satur_MT – Saturated Steam - Measure Temperature
7. Satur_ST – Saturated Steam - Set Temperature
8. Satur_MP – Saturated Steam - Measure Pressure
9. Satur_SP – Saturated Steam - Set Pressure
10. Super_MTMP – Superheated Steam - Measure Temperature and Measure Pressure.
11. Super_MTSP – Superheated Steam - Measure Temperature and Set Pressure.
12. Super_STMP – Superheated Steam - Set Temperature and Measure Pressure.
13. Super_STSP – Superheated Steam - Set Temperature and Set Pressure.

7.5.11 CompSetTemp

Compensation with Set the value of Temperature. This parameter is to set the temperature, and the unit is °C.

7.5.12 CompSetPress

Compensation with Set the value of Pressure. This parameter is to set the pressure, and the unit is kPa.

7.5.13 RTD Sel

This parameter is set when the flow meter with temperature and pressure compensation function. Select the type of thermal resistance of the temperature measurement channel, Two types are available: PT100 and PT1000.

7.5.14 PressMax

The upper range of the pressure transmitter or pressure sensor (the lower limit defaults to 0).

7.5.15 VoltageMin/ VoltageMax/ Sensor Type

Sensor type has the following types: Gauge pressure sensor, absolute pressure sensor, gauge pressure transmitter, and absolute pressure transmitter.

Pressure chooses the four-wire pressure sensor.

Pressure sensor requirements: 5 V active power supply, the lower pressure source is set to 0, and the upper pressure source is set to 100.

7.5.16 AtmSet

The factory default is 101.325 kPa. For actual values, please refer to the local actual atmospheric pressure setting.

7.5.17 Press Unit

The factory default is Pa, and can choose Pa, kPa, MPa.

7.5.18 Press Cut Off

Cut off according to the percentage of pressure. And steady indication

zero when the pressure is lower than the set value.

7.6 Instrument On-site Debugging

If the instrument is calibrated according to the actual site conditions, only one parameter of the "Noise Cutoff" needs to be adjusted on site. Usually the on-site noise is larger than the calibration, so the "Noise Cutoff" can be adjusted to a larger degree to remove the interference noise. Note: adjust the "Noise Cutoff" to a larger degree will sacrifice the lower limit of the flow measurement.

"LowFlow Cutoff" can achieve no flow metering when the flow is very small. Need to cut off small flow according to the actual situation on site. The factory default is 0, that is, it is not cutoff.

7.7 Total Reset

Press the "ENTER" button on the main screen to enter the total clear password. Enter the parameter interface and select "Total Clear". Press the "ENTER", and the total flow is cleared.

7.8 Communication Mode Selection

The vortex converter has two modes of communication: Hart communication and RS485 communication. The model of the flow meter determines the communication mode. Select a flow meter with the communication function, otherwise it will be invalid.

7.9 Temperature and Pressure Compensation Function

The compressibility of the gas determines that its flow measurement is more complex than liquid. Flow is related to the input signal and also related to gas density. The density of the gas is a function of temperature and pressure. Therefore, the measurement of gas generally needs temperature and pressure compensation. Fluid density varies with temperature and pressure, the "fluid density" parameter sets the density under standard conditions. And in order to get the density under working conditions, then temperature and pressure compensation is needed. It realizes the conversion of volume flow and mass flow under standard conditions and working conditions. In addition, the calculation of the working condition flow with compensation is realized.

The source of pressure and temperature for compensation can be

selected by the "CompensMode" parameter. When compensation by set the values, the parameters of temperature and pressure comes from working conditions. When compensation by measure, the value of temperature and pressure comes from real-time acquisition.

Under compensation, Pressure unit kPa, temperature unit °C.

The theoretical basis for the temperature and pressure compensation of the gas is carried out by the ideal gas equation. However, the relationship between temperature, pressure and volume deviates from the ideal gas equation under non-standard working conditions. Using a gas compression factor can compensate this deviation.

Compensation for saturated steam: Because the temperature and pressure of saturated steam correspond one-to-one, the compensation of saturated steam only needs to know one value of the temperature or pressure to compensate.

Superheated steam: Both temperature and pressure are required to compensate.

Notes:

- This parameter is for gas, superheated steam and saturated steam. Therefore, it is compensated when the medium is measured as gas. This is, the "Fluid Type" parameter is set to Gas.
- Fow meter series with the temperature and pressure compensation function must be selected if the compensation function is required.

8 Troubleshooting

Symptom	Check	Corrective Action
Communication problems with HART-based Communicator	<ul style="list-style-type: none"> • Check for a minimum of 24 V at transmitter terminals. • Check communications loop with HART-based communicator. • Check for loop resistor (\geq 250 ohms). 	<ul style="list-style-type: none"> • Remove pulse connection if you have a three wire pulse installation. • Replace electronics.
Incorrect 4–20 mA Output	<ul style="list-style-type: none"> • Check 24 V power supply at transmitter terminals • Check range setting and modify the configuration • Check output mode and modify the configuration • Disconnect current output loop and test if there is any additional voltage. 	<ul style="list-style-type: none"> • Disconnect current output loop, test whether the output current is correct by multimeter; • Check for corrosion on terminal block. • Replace electronics if necessary.
Incorrect Pulse Output	<ul style="list-style-type: none"> • Check the range setting and modify the configuration. • Check output mode setting and modify the configuration. 	<ul style="list-style-type: none"> • Replace electronics if necessary.
Flow in Pipe, No Output	<ul style="list-style-type: none"> • Basics Check to make sure that the meter is installed with the arrow in the direction of process flow. • Perform basic checks for incorrect 4–20 mA Output Problem (see incorrect 4–20 mA Output). • Check and modify the configuration as following: • Check size and flow range within the measurable flow range. Check output frequency 	<p>Application Problems</p> <ul style="list-style-type: none"> • Check that application meets viscosity and specific gravity requirements for the line size. • Recalculate back pressure requirement. If necessary and possible, increase back pressure, flow rate, or operating Pressure. • Sensor • Inspect coaxial sensor cable for cracks.

9 Disposal or Waste



Electronic devices are recyclable material and do not belong in the household waste.

The sensor, the accessories and its packings must be disposed according to your local statutory requirements. The dispose can also be carried by the manufacturer of the product, for this please contact the manufacturer.

10 Appendix A: Flow Measurement Range

Saturated Steam Mass Flow Rate

DN (mm)	Saturated Steam Mass Flow Rate (t/h)											
	0.1 MPa		0.2 MPa		0.3 MPa		0.4 MPa		0.5 MPa		0.6 MPa	
DN50	0.04	0.35	0.04	0.52	0.05	0.68	0.06	0.83	0.06	0.99	0.07	1.14
DN65	0.06	0.6	0.08	0.87	0.09	1.14	0.1	1.41	0.11	1.67	0.11	1.93
DN80	0.1	0.9	0.12	1.32	0.13	1.73	0.15	2.13	0.16	2.53	0.17	2.93
DN100	0.15	1.41	0.18	2.06	0.21	2.7	0.23	3.33	0.25	3.96	0.27	4.58
DN125	0.23	2.2	0.28	3.22	0.32	4.22	0.36	5.21	0.39	6.18	0.42	7.15
DN150	0.33	3.17	0.4	4.64	0.46	6.08	0.51	7.5	0.56	8.9	0.6	10.3
DN200	0.6	5.64	0.72	8.25	0.82	10.8	0.91	13.33	1	15.83	1.07	18.31
DN250	0.93	8.81	1.12	12.88	1.29	16.88	1.43	20.82	1.56	24.73	1.68	28.61
DN300	1.34	12.69	1.62	18.55	1.85	24.31	2.06	29.99	2.24	35.61	2.41	41.2

Saturated Steam Mass Flow Rate (Continued 1)

DN (mm)	Saturated Steam Mass Flow Rate (t/h)									
	0.7 MPa		0.8 MPa		0.9 MPa		1.0 MPa		1.1 MPa	
DN50	0.07	1.29	0.08	1.45	0.08	1.61	0.08	1.76	0.09	1.91
DN65	0.12	2.18	0.13	2.45	0.13	2.71	0.14	2.97	0.15	3.23
DN80	0.18	3.3	0.19	3.72	0.2	4.11	0.21	4.5	0.22	4.89
DN100	0.28	5.16	0.3	5.81	0.32	6.42	0.33	7	0.35	7.65
DN125	0.44	8.06	0.47	9.08	0.5	10.04	0.52	11	0.54	11.95
DN150	0.64	11.61	0.68	13.07	0.71	14.45	0.75	15.83	0.78	17.21
DN200	1.14	20.64	1.21	23.24	1.27	25.69	1.33	28.14	1.39	30.6
DN250	1.78	32.25	1.89	36.31	1.98	40.15	2.1	44	2.2	47.8
DN300	2.56	46.45	2.72	52.28	2.86	57.81	3	63.3	3.12	68.8

Saturated Steam Mass Flow Rate (Continued 2)

DN (mm)	Saturated Steam Mass Flow Rate (t/h)									
	1.2 MPa		1.3 MPa		1.4 MPa		1.5 MPa		1.6 MPa	
DN50	0.09	2.06	0.09	2.22	0.1	2.37	0.1	2.52	0.1	2.67
DN65	0.15	3.49	0.16	3.75	0.16	4	0.17	4.26	0.17	4.52
DN80	0.23	5.28	0.24	5.68	0.25	6.07	0.25	6.45	0.26	6.84
DN100	0.36	8.26	0.37	8.87	0.39	9.48	0.4	10.08	0.41	10.69
DN125	0.56	12.9	0.58	13.86	0.6	14.81	0.62	15.76	0.64	16.71
DN150	0.81	18.58	0.84	19.95	0.87	21.32	0.9	22.69	0.92	24.06
DN200	1.44	33.03	1.49	35.48	1.54	37.91	1.59	40.34	1.64	42.78
DN250	2.25	51.61	2.33	55.43	2.41	59.23	2.49	63.03	2.56	66.84
DN300	3.24	74.31	3.36	79.82	3.47	85.29	3.58	90.76	3.69	96.25

11 Appendix B: Modbus Communications

11.1 Introduction

S435 provides the standard Modbus communication interface. Its baud rates can be 300, 600, 1200, 2400, 4800, 9600, 19200, 38400, 57600, or 115200. Through the Modbus communication network, hosts can collect instantaneous flow, accumulative flow, and so on.

The serial port parameters that S435 uses: 1 start bit, 8 data bits, 1 stop bit, none parity bit.

S435 Modbus communication port is electrically isolated in the physical structure. The isolation voltage is 1500 V with ESD protection, avoiding various interferences from industrial scene and ensuring the reliability of communication network.

11.2 Modbus Networking and Wiring

The standard Modbus communication network is a bus network, which can support 1 to 99 flow meters. The flow meter at the farthest end of the network usually requires to connect a 120-ohm terminal matching termination resistor in parallel. The standard communication connection media is shielded twisted pair.

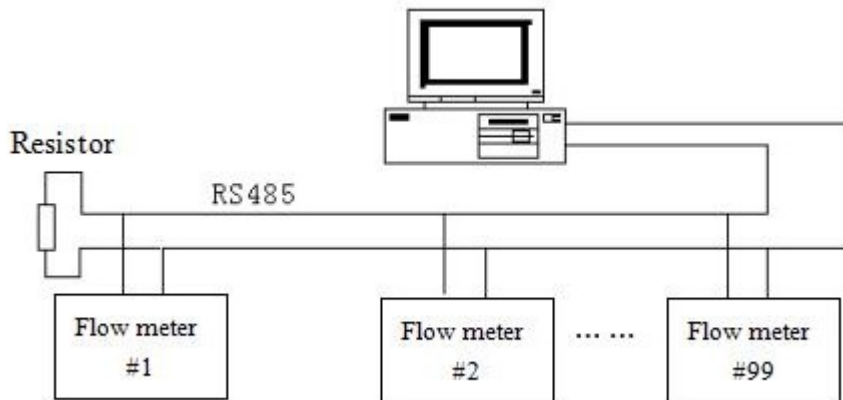

Networking diagram

11.3 Modbus Messages in RTU Framing

S435 uses the Modbus/RTU framing format (hexadecimal format). Its frame format is shown in section 11.3.1.

11.3.1 Master Order Frame Structure

Master RTU message frame

Start	Device address	Function code	Register address	Register length	CRC	Stop
T1-T2-T3-T4	8Bits	8Bits	16Bits	16Bits	16Bits	T1-T2-T3-T4

11.3.2 Slave response frame structure

Slave RTU message frame

Start	Device address	Function code	Data	CRC	Stop
T1-T2-T3-T4	8Bits	8Bits	n 8Bits	16Bits	T1-T2-T3-T4

Notes:

- T1-T2-T3-T4 is the start or stop frame. The Modbus protocol defines that every two frames must have at least a 3.5-char delay. See below figure for reference.

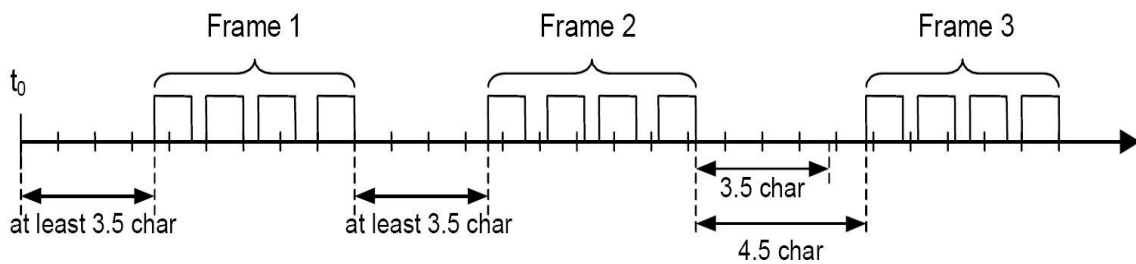

Modbus frame interval

- Device address: This is S435's communication address. Two identical addresses are not allowed in a network.
- Function code: Defined by the Modbus protocol. S435 uses the function code 03, which realizes the data collection using the read holding register.
- Register address and the number of registers: The master reads data from the consecutive N registers that starts from the "Register address". N is defined in the "Register length".
- Slave response data: The number of bytes and N bytes. See more details in the Modbus protocol.

11.4 Function Codes

Modbus function codes are listed in below table. S435 only uses 03 code.

Function code	Name	Function
01	Read coil status	reservation
02	Read input status	reservation
03	Read holding registers	read S435 real-time information
04	Read input register	reservation
05	Strong set single coil	reservation
06	Preset single register	reservation
15	Strong multi-coil set	reservation
16	Input multiple register	reservation

11.5 Definition of addresses

Modbus addresses is defined as follows:

Data type	Starting address
Coils (output)	00001
Digital Inputs	10001
Analog Inputs	30001
Holding Registers	40001

S435 only uses Holding Registers.

11.6 Modbus Registers

11.6.1 S435 Data Type

Basic data type	Data width (Bit)	Description	Range
BOOL	1	BOOL	0 ~ 1
BYTE	8	BYTE	16#00 ~ 16#FF
WORD	16	WORD	16#0000 ~ 16#FFFF
DWORD	32	Double word	16#00000000 ~ 16#FFFFFFFF

Basic data type	Data width (Bit)	Description	Range
SINT	8	Single integer	-128 ~ 127
INT	16	Integer	-32768 ~ 32767
DINT	32	Double integer	-2147483648 ~ 2147483647
USINT	8	Unsigned single integer	0 ~ 255
UINT	16	unsigned integer	0 ~ 65535
REAL	32	Real number	
UDINT	32	Unsigned Double integer	0 ~ 4294967295

11.6.2 Modbus Register Addresses

No.	Modbus Address (Decimal)	Protocol address (Physical Address) (Decimal)	Data format	Register definition	Unit	Note
1	40151	150	REAL	Instantaneous flow	Refer to "Instantaneous flow unit" register	P&T compensation series product. This value is after compensation.
2	40153	152	DWORD	Instantaneous flow unit\	blank	NA
3	40155	154	DWORD	Integer part of the cumulative value	Refer to "Instantaneous flow unit" register	P&T compensation series product, This value is after compensation.
4	40157	156	REAL	Decimal part of the cumulative	Refer to "Cumulative flow	P&T compensation series

No.	Modbus Address (Decimal)	Protocol address (Physical Address) (Decimal)	Data format	Resister definition	Unit	Note
				value	unit"register	product, This value is after compensati on.
5	40159	158	DWORD	Cumulative total units	blank	NA
6	40161	160	REAL	Temperatur e value	°C	Only valid for P&T compensati on series product
7	40163	162	REAL	Pressure value	Refer to"Pressure unit"register	Only valid for P&T compensati on series product
8	40165	164	DWORD	Pressure unit	blank	NA
9	40167	166	REAL	Working condition density	kg/m ³	P&T compensati on series product. This value is after compensati on.
10	40169	168	REAL	Flow percentage	%	Instantane ous flow/range *100
11	40055	54	REAL	K-factor	L/P	NA

Notes:

- **Modbus Address:** Refers to the Modbus standard address. The first two digits "40" indicate the Modbus holding registers. The last three digits indicate the address of the holding register. With the address starting at 1; address 40100 represents the 100th holding register.
- **Protocol address:** Refers to the address that is transmitted in the Modbus-protocol messages. The address starts at 0, therefore the protocol address of the 100th holding register is 099.

- **The relationship of "Modbus address" and "protocol address":**

"Modbus address", starts at 1; Because the function code already specifies the type of address variable represented by the address. In fact, the first two bits of the "Modbus address" are transmitted in the messages. So only the last 3 bits are valid.

"Protocol address" is the address obtained by subtracting "1" from the "Modbus address" that is removed the first two bits. The "Protocol address" is the address that is used in the protocol transmission. Because the "protocol address" starts from 0, and the "Modbus address" starts from 1, so subtracting "1" is needed.

When the communication starts, by subtracting 1 from the last 3 digits of the "Modbus Address", you can get the "protocol address". "Protocol address" is the address used in the communication. Many of software products installed on the master stations use "Modbus address", so the user interface of the PLC and other master devices uses the "Modbus address". However, in the transmission protocol, only the "Protocol address" converted from the "Modbus address" participates in the underlying communication.

11.6.3 Description of Data

Unit code definition:

Instantaneous flow unit		Cumulative flow unit		Cumulative flow unit	
Code	Instantaneous flow unit	Code	Cumulative flow unit	Code	Pressure unit
0	m ³ /h	0	m ³	0	Pa
1	Nm ³ /h	1	Nm ³	1	kPa
2	kg/h	2	kg	2	MPa
3	t/h	3	t		

11.7 Communication Data Analysis

Instantaneous flow, flow percentage, and the decimal part of the cumulative positive value are transmitted in the floating point numbers. The integer part of the cumulative positive value is transmitted as a long integer.

11.7.1 Read Instantaneous Flow

Master sends command (hexadecimal number)

01	03	00	96	00	02	24	27
Device address	Function code	Register high address	Register low address	Register high length	Register low length	CRC low	CRC high

Data that master receives from Slave (hexadecimal number)

01	03	04	C4	1C	60	00	2E	C5
Device address	Function code	Data length	4 bytes float (instantaneous flow)				CRC low	CRC high

Float: C4 1C 60 00
 1100 0100 0001 1100 0110 0000 0000 0000
 byte 1 byte 2 byte 3 byte 4

S=1: if mantissa symbol is 1, it is a negative.

E=10001000: Exponent is 136

M=001 1100 0110 0000 0000 0000, The mantissa is:

$$V = (-1)^1 2^{(136 - 127)} \left(1 + \frac{1}{8} + \frac{1}{16} + \frac{1}{32} + \frac{1}{512} + \frac{1}{1024} \right)$$

$$= -625.5$$

Note:

Floating-point format:

S435 Modbus uses IEEE754, 32-bit floating-point format. Its structure is shown as follows: (Take the instantaneous flow as an example.)

0X1010 (34113)		0x1011 (34114)	
BYTE 1	BYTE2	BYTE3	BYTE4
S EEEEEEE	E MMMMMMM	MMMMMMMM	MMMMMMMM

S- Mantissa symbol; 1=negative, 0=positive.

E- Exponent; expressed by the difference with decimal number 127.

M- Mantissa; low 23 bits and the decimal part.

When not all of the E is "0" and "1", the conversion formula between floating-point and the decimal number is:

$$V = (-1)^S 2^{(E-127)} (1 + M)$$

11.7.2 Read Cumulative Flow

To express the cumulative value of S435 in full, the integer part and decimal part of the cumulative flow are expressed respectively. The integer part uses the long variable and the decimal part uses floating-point number.

Suppose that the cumulative flow is 28785.5m³, it includes 2 parts: Integer value of 28785 and Decimal value of 0.5.

Integer value of the cumulative flow is 28785 m³.

Master sends a command to collect the integer value of cumulative flow from the slave (hexadecimal number)

01	03	00	9A	00	02	E4	24
Device address	Function code	First Register address (high)	First Register address (low)	Number of Registers requested (high)	Number of Registers requested (low)	CRC low	CRC high

Data that the master receives from the slave:

01	03	04	00	00	70	71	1F	D7
Device address	Function code	Data length	4 bytes floating-point (integer value of cumulative flow)			CRC low	CRC high	

Decimal value of cumulative flow is 0.5m³.

Master sends a command to collect the decimal value of cumulative flow from the slave (hexadecimal number)

01	03	00	9C	00	02	04	25
Slave address	Function code	First Register address (high)	First Register address (low)	Number of Registers requested (high)	Number of Registers requested (low)	CRC low	CRC high

Data that the master receives from the slave:

01	03	04	3F	00	00	00	F6	01
Slave address	Function code	Number of data bytes	4 bytes floating-point numbers (decimal value of cumulative flow)				CRC (low)	CRC (high)

Floating-point number: 3F 00 00 00
 0011 1111 0000 0000 0000 0000 0000 0000

S=0
 E= 0111111 126
 M= 000 0000 0000 0000 0000 0000

$$V = (-1)^1 2^{(126 - 127)}$$

$$= 0.5$$

SUTO iTEC GmbH

Grißheimer Weg 21
D-79423 Heitersheim
Germany

Tel: +49 (0) 7634 50488 00
Email: sales@suto-itec.com
Website: www.suto-itec.com

SUTO iTEC (ASIA) Co., Ltd.

Room 10, 6/F, Block B, Cambridge Plaza
188 San Wan Road, Sheung Shui, N.T.
Hong Kong

Tel: +852 2328 9782
Email: sales.asia@suto-itec.com
Website: www.suto-itec.com

SUTO iTEC Inc.

5460 33rd St SE
Grand Rapids, MI 49512
USA

Tel: +1 (616) 800-7886
Email: sales.us@suto-itec.com
Website: www.suto-itec.com

All rights reserved ©

Modifications and errors reserved

S435_im_en_2023-1