



**COMAC CAL**

**CZECH PRODUCER  
AND DEVELOPER  
OF MEASUREMENT  
AND SENSOR TECHNOLOGY**

# **FLOW 33Exia MGD**

1.10

*Installation and technical conditions*

**Date of issue 12/12/2016**

[WWW.COMACCAL.COM](http://WWW.COMACCAL.COM)

## ***Contents:***

<b><i>Description of device</i></b> .....	<b>3</b>
Scope of delivery .....	3
<b><i>Storage conditions</i></b> .....	<b>5</b>
<b><i>Warranty</i></b> .....	<b>5</b>
<b><i>Installation in pipeline</i></b> .....	<b>6</b>
Important information for selection of location .....	6
Sources of disturbances .....	6
Installation examples .....	7
Actual installation in pipeline .....	8
Installation check .....	13
<b><i>Wiring</i></b> .....	<b>14</b>
Meter wiring .....	14
Wiring check .....	17
<b><i>Putting into operation</i></b> .....	<b>18</b>
<b><i>Technical data</i></b> .....	<b>20</b>
<b><i>Safety information</i></b> .....	<b>22</b>
<b><i>Factory settings</i></b> .....	<b>24</b>
<b><i>Table with flow ranges for individual DN sizes</i></b> .....	<b>25</b>
<b><i>Basic sensor sizes</i></b> .....	<b>26</b>
<b><i>Nomogram for quick proposal of the measured place</i></b> .....	<b>30</b>
<b><i>Reduction in DN pipe</i></b> .....	<b>30</b>
<b><i>Failures and their symptoms during measurement</i></b> .....	<b>31</b>
<b><i>Flow sensor cleaning</i></b> .....	<b>31</b>
<b><i>Service</i></b> .....	<b>31</b>
<b><i>Order code</i></b> .....	<b>32</b>
<b><i>Form for returning the meter to COMAC CAL s.r.o.</i></b> .....	<b>33</b>

## ***Description of device***

The FLOW 33Exia meter is based on measurement principle by a well-known Faraday's electromagnetic induction law according to which an electric voltage is induced during the flow of a conductive liquid through the flow meter magnetic field. This is picked up by two electrodes in direct contact with the measured medium and evaluated in the electronic unit.

The FLOW 33Exia type of induction meters are suitable exclusively for measurement of volumetric flow of electrically conductive liquid substances with a minimum conductivity of 20  $\mu\text{S}/\text{cm}$  (at a lower conductivity, upon agreement with the manufacturer).

Meters are designed for flow measurement where the velocity of liquid is in the range of  $0.01 \div 12$  m/s. The best measurement accuracy can be obtained in the range of  $1 \div 10$  m/s.

Flow 33Ex are firmly integrated in the pipe system of underground mine, chemical or other application where exist the risk of explosive gases and dusts. They are formed by corundum measuring pipe in diameter DN 15, DN 25, DN 32, DN 40, DN 50, DN 65 and DN 80 or stainless steel measuring pipe with rubber or PTFE lining in DN15, DN 20, DN 25, DN 32, DN 40, DN 50, DN 65, DN 80, DN 100, DN 125, DN 150 and DN 200. Pipes are inside stainless steel housing fitted with different types of process connection. On the housing is fixed stainless steel cover for evaluation unit with electronics of sensor, which is fitted with stainless steel top cover equipped with connector for wiring of flowmeter to next devices.

The entire inner space of flowmeter is filled with sealing compound for protection against humidity and increase protection against ignition of surrounding atmosphere in the hazardous area. Therefore, after filling of the whole system is flowmeter disassembled and any changes in construction are not possible.

## **Scope of delivery**

Accessories vary according to the variant of flow sensor and above standard optional features.

### ***Threaded design***

Electronic evaluation unit in a compact design (the electronic unit is integral part of the flow sensor), flow sensor, connecting grounding cable, installation manual.

### ***Sandwich design***

Electronic evaluation unit in a compact design (the electronic unit is integral part of the flow sensor), flow sensor, bolts for installation of the sensor between flanges (quantity as per tightening torque table, see below) with nuts and washers, connecting grounding cable, installation manual.

### ***Flanged design***

Electronic evaluation unit in a compact design (the electronic unit is integral part of the flow sensor), flow sensor, connecting grounding cable, installation manual.

### ***Food industry design***

Electronic evaluation unit in a compact design (the electronic unit is integral part of the flow sensor), flow sensor, adapter piping connection according to DIN 11851, installation manual.



## ***Storage conditions***

The temperature during transportation and storage of the meter must be within the range of -10 °C to 50 °C.

Wooden boards installed on the flanges in the factory are used for protection of lining on the flanges during storage and transportation (for PTFE lining). Remove these protective boards just before installing in the pipeline!!!

Do not lift the flanged meters by the transducer head or by the connecting box of the detached design during transportation! Use slings and place them round both process connections for transportation of meters up to DN125 (chains may damage the meter head)! Use only the metallic lugs on the flange for transportation, lifting and installation of the sensor in piping in case of DN150 and bigger!!!

## ***Warranty***

Unprofessional installation or using the induction meters (devices) may result in a loss of warranty as well as failure to comply with installation or operating conditions according to this manual.

In case of returning the meters for inspection or repair to the COMAC CAL s.r.o. factory, enclose please the completed form, see the last page of this manual. Without having one, we will not be able to handle your requirement for modification or possibly repair your meter correctly and promptly.

## *Installation in pipeline*

### **Important information for selection of location**

#### *Outdoor conditions*

It is necessary to ensure that the flow sensor is not exposed to weather effects and that the measured medium cannot freeze in the flow sensor as it would damage the measuring tube.

In case of outdoor location of the electronic evaluation unit, the manufacturer recommends using a protective box or a roof to avoid direct solar exposure so that the evaluation electronics cannot get overheated.

- Operating ambient temperature (full function) from 0 °C to + 44 °C
- Limited increased ambient temperature (without function) up to + 55 °C
- Limited decreased ambient temperature (without function)) up to - 30 °C
- Relative ambient humidity with 25 °C up to 100 %

Based on characteristic of the used components is F33 Ex placed in a group II.B with maximal temperature < 60 °C

### **Sources of disturbances**

The following items rank among the most frequent sources of disturbances to the steady flow of liquid:

- Abrupt changes in pipe cross-section if not performed as a cone with an angle of  $\alpha \leq 7^\circ$  (where  $\alpha$  is the angle made by bevelled walls of the pipe reduction).
- Incorrectly centred sealing, low ID sealing or sealing made of soft elastic materials which are pushed out into the interior pipe cross-section after flanges are tightened.
- Anything interfering in the flow of liquid, for example thermowells, branch pipes, T-pieces, bends, elbows, slide valves, cocks, flap valves, shut-off valves, control valves, butterfly valves and check valves. Pipe outlets from tanks, heat exchangers and filters.
- No intensive magnetic fields in the proximity of the induction flow sensor (detector) must be present.

**No sources of disturbances** affecting the steady flow must be present in the straight pipeline sections. They must be located in the piping after the flow sensor or at the farthest distance before it. Sources of disturbances may substantially reduce the measuring range and accuracy of the flow meters.

#### *Vibration*

We recommend supporting the connecting pipes on both sides of the meter for partial elimination of vibrations. Levels and range of vibrations must be under 2.2 in the frequency range of 20 ÷ 50 Hz according to IEC 068-2-34. If the pipeline is exposed to excessive vibrations (e.g. from pumps), using compact meters is not recommended.

#### *Actual location*

The flow sensor (detector) must not be at the top position of the pipe which may be airlocked, or in declining or even in horizontal pipelines with open ends in which air may penetrate. Impurities may accumulate during long-term measurement of very low flow rates  $Q < 0.1$  m/sec. There must be a

sufficient pressure in the place of flow sensor installation so that the expulsion of gas or vapour bubbles from the liquid is avoided. Little bubbles that always occur in liquids may accumulate at any of the electrodes and this may result in incorrect operation of the meter. Gas bubbles are expelled also at an abrupt pressure drop. Therefore, butterfly valves and similar elements should be located **after the flow sensor**. For the same reason, the flow sensor should not be placed at the suction side of the pump. To prevent the bubbles from accumulation at a low flow in the flow sensor, it is suitable, e.g. that the pipe is slightly ascending or that the flow sensor is located in the vertical section of the pipeline.

It is necessary for proper function of the meter, to fill up the flow sensor with the fluid to be measured so that erroneous readout of quantity of liquid passing through the meter can be avoided when the pipe is empty. It is necessary to select the location of the meter in such a way that the flow sensor aeration can be avoided. In the case of an open system, the flow sensor is placed in the bottom position of the U-profile pipework, ensuring that the fluid will not flow out of the sensor.

*In case of any intervention into the measuring circuit must be accessed like a pipe is fulfilled of medium, and regardless of the displayed information “empty pipe test” on the meter LED !!!*

### Installation examples

Trouble-free and exact operation of the meter is dependent on its correct location in the system. The most frequent methods of the placement are shown in the following figures:

#### Recommended installation locations

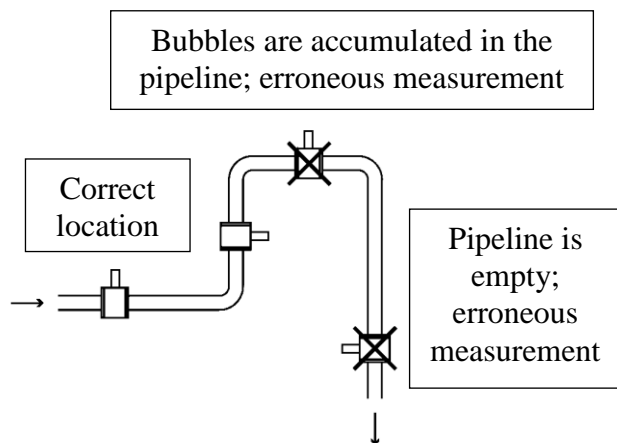

#### Downtake pipe

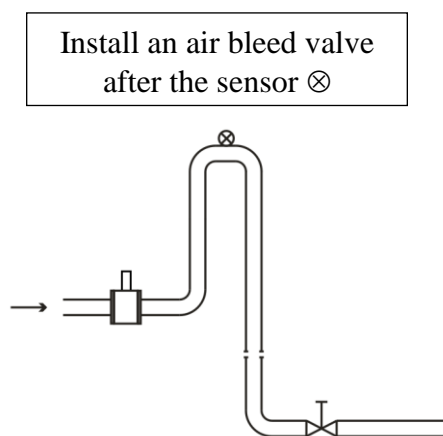

#### Horizontally laid pipeline

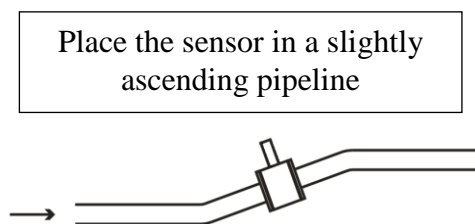

#### Long pipeline

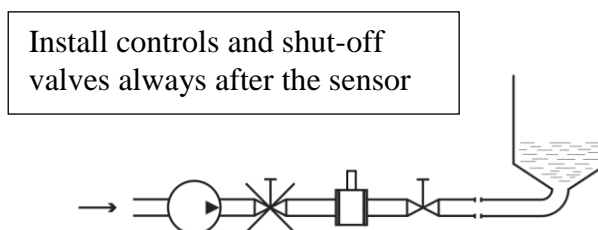

## Free inlet or outlet

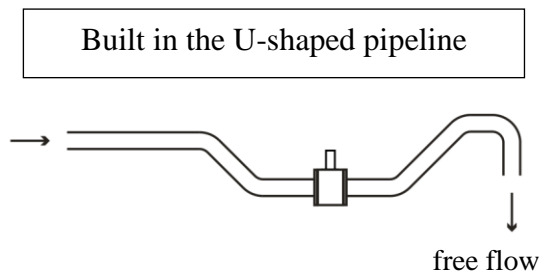

## Pumps

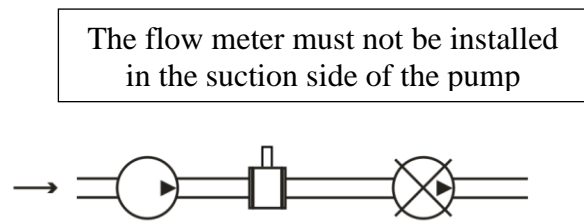

The flow of liquid flow in the flow sensor should be **steady and free of whirling**. For this reason, straight sections of pipeline with the same ID as that of the flow meter before and after the flow sensor (with permissible deviation of +5%). Recommended minimum length of straight sections is  $5 \times d$  before the flow sensor and  $3 \times d$  after the flow sensor where  $d$  is the inside diameter of the meter in millimetres. The same principles apply before and after the flow sensor in case of bi-directional flow measurement.

## Recommendations

- In case of whirled up flow, extend the calming sections of pipeline or integrate a flow conditioner.
- When blending a mixture of substances, it is necessary to install the flow meter either before the point of blending or at a sufficient distance after it ( $30 \times d$  min. where  $d$  is the inside diameter of the meter in millimetres), otherwise it will result in instability of indication.
- When plastic pipeline is used or in case of metallic pipes with internal non-conductive layer, earthing rings are needed.
- Do not install the sensor at the suction side of the pumps; this will eliminate the risk of vacuum and possible damage to the measuring tube lining.
- Pumps, bends and elbows found closely in succession in various levels should be at a distance of  $20 \times d$  at least before the flow sensor. In case of a separate elbow or bend, the placement  $10 \times d$  before the meter is recommended.
- When piston pumps, diaphragm pumps, and flexible tube pumps are used, it is necessary to install a pulse damper in the system.
- In order to provide the highest accuracy, it is important to ensure permanent flooding for the sensor (for example, by installation of the sensor in the U-shaped pipeline) even if the sensor is equipped with empty tube test. This will serve as an additional safety measure for detection of non-flooded tube.

The responsibility for suitability and adequacy of application of induction flow meters is borne by the designer or possibly the user himself.

## Actual installation in pipeline

When welding both counter-flanges to the pipelines, it is necessary to maintain their **alignment** so that levelness of bearing surfaces of the flanges onto the front faces of the detector is ensured (at the same time, this must not be achieved by unequal tightening of the bolts as there is a risk of leakage due to thermal loading in the future or the measuring tube may break during such tightening). The difference of  $L_{MAX}$  and  $L_{MIN}$  distances of the sealing surfaces of the flanges before the flow sensor is installed **must not be greater than 0.5 mm**.



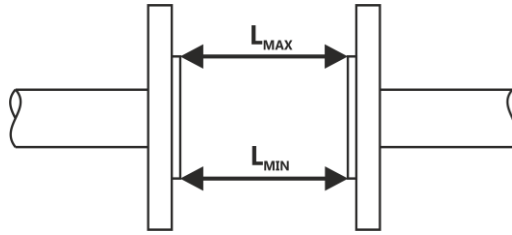

The opposition of the holes in the counter-flanges for the bolts should be ensured in the same manner and a sufficient room behind the flanges should be available for the bolts and nuts so that the actual installation of the sensor in pipeline and its attachment with the bolts is made possible.

The manufacturer recommends using an intermediate piece during welding. It is absolutely excluded to use the flow sensor as an intermediate piece due to thermal damage. The welding current must not run through the flow sensor during electrical welding. The installation of the flow sensor is carried out after welding, coating, building and similar works are completed.

The actual installation is performed by the fixation between the counter-flanges that are welded to the calming pipeline ( $5 \times d$  before and  $3 \times d$  in the direction of flow) whereas the liquid must run through the flow sensor in the direction **indicated by the arrow** on the sensor name plate.

During installation, do not lift the meter by the evaluation unit housing, possibly under the meter's metallic housing but always use slings round the process connection or use the lifting lugs on the flanges.

*Installation position*

The inductive flow sensor is installed in arbitrary position in vertical piping. In case of horizontal piping, it is necessary to make sure that the sensor is installed with its measuring electrodes in horizontal position.

*Installation in piping and placement of measuring electrodes in flow sensor*

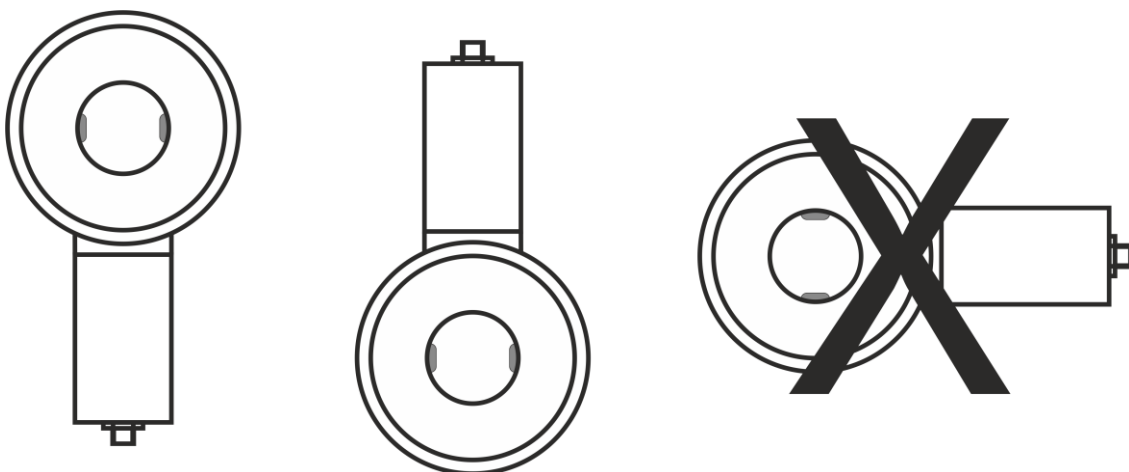

During installation, beware of:

- dropping the meter onto the ground and damaging the measuring tube or electronics
- contamination of the electrodes (do not touch the electrodes, otherwise they get contaminated)
- when additional sealing is used, avoid its interference in the flow profile of the detector between the flanges and the pipeline, otherwise the flow measurement error may be increased

#### Tightening torques

It is absolutely necessary to tighten the bolts and nuts equally by alternating sides and in the order shown in figure applying the maximum torque according to the table.

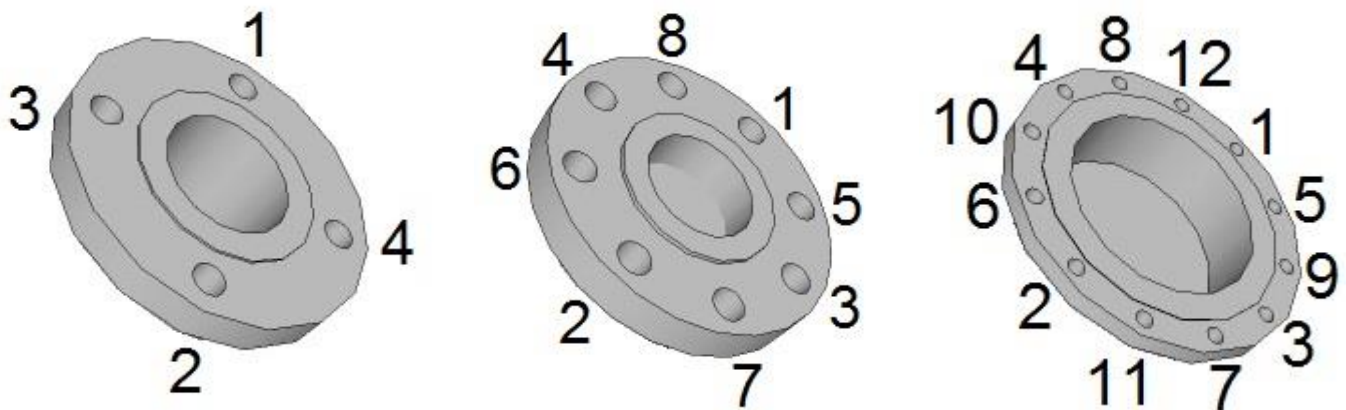

If the bolts are tightened too much during the installation of pipework components, deformation of the sealing surface may occur. In consequence, the torque values indicated in the table are used as a guidance for tightening the screws and bolts.

Table with tightening torques for screws/bolts:

Diameter nominal DN	PN 10		PN 16	
	Screws	Tightening torque [Nm] Rubber   PTFE	Screws	Tightening torque [Nm] Rubber   PTFE
15		20   25		20   25
20	4 x M12	20   25	4 x M12	20   25
25		20   25		20   25
32		20   25		20   35
40	4 x M16	20   25	4 x M16	20   35
50		20   45		20   45
65		20   46		20   46
80		20   48		20   48
100	8 x M16	20   50	8 x M16	20   50
125		20   80		20   80
150	8 x M20	24   90	8 x M20	27   90
200		25   115	12 x M20	28   80
250	12 x M20	27   95		38   110
300		34   115	12 x M24	55   150
350	16 x M20	47   140	16 x M24	75   160
400	16 x M24	65   155	16 x M27	85   200

Diameter nominal DN	PN 25			PN 40		
	Screws	Tightening torque [Nm]		Screws	Tightening torque [Nm]	
		Rubber	PTFE		Rubber	PTFE
15		25	25		25	25
20	4 x M12	25	25	4 x M12	25	25
25		25	25		25	25
32		25	35		25	40
40	4 x M16	25	35	4 x M16	35	50
50		35	45		35	60
65	8 x M16	35	46	8 x M16	45	55
80		40	48		45	60
100	8 x M20	40	55	8 x M20	50	75
125	8 x M24	50	110	8 x M24	70	120
150		57	115		75	136
200	12 x M24	68	100	12 x M27	85	145
250	12 x M27	88	120	12 x M30	105	-
300	16 x M27	95	125	16 x M30	115	-
350	16 x M30	115	200	16 x M33	140	-
400	16 x M33	135	255	16 x M36	165	-

The flanged connection design corresponds to EN 1092-1.

In case of using a corundum or thermoplastic tube, the same torques apply as in case of using the PTFE tube according to the given pressure series.

If you do not find your size or structure in the Torque Table, it is a special or non-standard design. In such a case, contact the manufacturer for more detailed information.

It is necessary to do the tightening three times, whereas for the first time, to 50% of the maximum torque according to the above given Table. For the second time, to 80% and for the third time, to 100% of the maximum torque. We recommend checking the screws/bolts for tightening some 24 hours after installation of the meter.

When installing the flow sensors over 200 mm, it is necessary to follow, except for the above mentioned rules, also simultaneous tightening of parallel screws on both opposite flanges to avoid possible damaging the electrodes or the measuring tube (symmetrical tensioning of the lining).

If the flanged joint is not tight, although all of the screws are tightened closely, **these must not be tightened more** but slackened on the opposite side to the untightness and tightened on the other side. If the untightness manifests itself even after that, it is necessary to check the sealing surfaces for scratches or mechanical impurities. If the scratches or any other damage are deeper than some 15% of the thickness of the flange, it is possible to remove them using fine emery paper.

In case of the threaded connection, it is necessary to check, while tightening, the screwed connection on the sensor so that torsional displacement is avoided.

### *Seal*

The turned up part of the lining does not carry out the function of sealing so it is necessary to insert the appropriate seal precisely centred between the sensor and the pipeline. If the sealing extends in some place into the flow profile, it makes whirls and reduces the measurement quality. Use the seals compatible with the liquid and 5mm thick. Do not use graphite or any other electrically conductive material to hold the sealing in place during installation. It could influence the measuring signal accuracy.

### *Earthing*

For reliable and correct operation of the induction sensor it is necessary to provide proper protective and working earthing. The earth line must not transmit interference voltages so the other electrical devices must not be earthed by means of this line.

The flow sensor is provided with the M5 earthing screw of stainless steel with a washer and nut for proper connection of the sensor body with both counter-flanges of the metallic pipeline. The earthing cable lug is screwed there and it should be conductively connected with the counter-flanges. On the counter-flanges, it is recommended their connection to the welded crews or into a threaded hole. Connecting under the fixing screws of the flange is not suitable as they may corrode with time and cause failures in measurement.

However, if it is not ensured that the counter-flanges are in direct contact with the measured media and they are conductive, the earthing rings must be used, refer hereinafter.

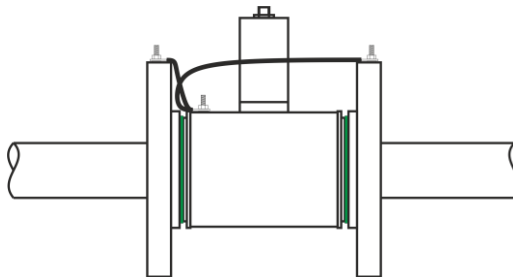

### *Earthing rings*

Using for a plastic pipeline or in case of metallic pipelines with internal plastic lining turned up or pulled out to the front faces of the pipeline flanges. Conductive earthing rings of stainless steel create conductive connection with the measured substance. Usually, potential equalization is carried out by means of the reference earthing electrode in the measuring tube. In exceptional cases, the equalizing currents may run through the reference electrode based on the device earthing conception. This may lead to deterioration of the sensor, e.g. by electrochemical disintegration of the electrodes. In such cases, it is **necessary** to use the earthing rings for potential equalization. This holds true for two-phase or two-component flows in which the medium is blended badly or its components cannot be blended. In general it can be said that using the earthing rings is always the protection against stray currents and the warranty of correct measurement at the same time.

The flow sensor is provided with the earthing screw of stainless steel for the earthing cable supplied with the mounting accessories. Then this cable must be conductively connected with the earthing rings.

The earthing rings are not part of our standard package and must be ordered separately. Chemical durability of the material must correspond with the liquid to be measured; it is usually made of the same material as the sensor electrodes. While mounting, it is necessary to insert seals in both sides of the earthing ring and take care that no part extends to the internal profile of the sensor (whirling and turbulence of the medium).

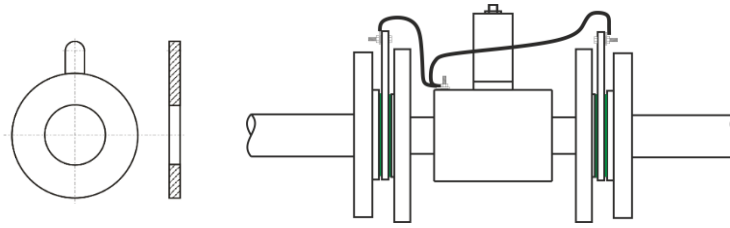

### *Electrodes*

The electrode material must be selected according to chemical resistance to the liquid to be measured. The purity of the electrodes may have an influence on measurement accuracy, their heavy fouling may cause even the interruption of the measuring function (isolation from the liquid). It is not necessary to clean the electrodes right after delivery before their installation in the pipeline. If the electrodes indicate signs of fouling, clean them with a soft cloth or use a chemical cleaning agent. Mind damaging to the lining! During routine operation, in case of a great majority of liquids, it is not necessary to clean the flow meter for the entire operation period of the flow sensor; self-cleaning by flow of the liquid is sufficient (recommended velocity is over 2 m/sec).

### *PTFE lining*

Meters with PTFE lining are equipped with protective covers to prevent the sealing surfaces from damaging during transportation or storage and from changing the shape (due to elastic memory of the PTFE material, it is restrained to the tube). Protective covers may be removed only right before the installation. If these covers are removed due to a check, it is necessary to replace them immediately.

Carry out the installation at the lowest point of the pipeline to avoid the occurrence of vacuum. Never detach and damage the rim of the PTFE lining turned up to the of flow sensor faces. Remove the covers from the inlet and outlet sides right before insertion of the sensor between the pipeline flanges and replace them with metal plates (0.3 ÷ 0.6 mm thick). After insertion of the sensor, remove the metal plates and install the screws/bolts.

## **Installation check**

After installation of the flow sensor in the pipeline, the following must be checked:

- According to the name plate, if there is a relevant meter in the given measuring point (pressure, temperature, dimension, etc.).
- If the direction of the arrow on the device is in agreement with the direction of the flow in the pipeline.
- Correct position of the measuring electrodes (horizontally).
- Correct position of the electrode for empty pipeline detection (up).
- If all bolts (screws) are tightened properly.
- If earthing rings are used, then their correct installation and connection with the sensor.
- Accuracy of flow sensor earthing.
- Accuracy of execution of the pipeline calming section lengths
- If the sensor is protected against vibrations and mechanical damage.

## Wiring

For use in conditions where is occurrence of explosion of gases and dust and gassy coal mines apply the following safety parameters and standards.

*Workers performing wiring are subject to the requirements of Decree No. 50/1978 Coll. on activities on electrical equipment!!!*

*When the following operations are performed unprofessionally, the claim on warranty for the resulting errors becomes extinct!!!*

*Prior to any manipulation with the meter, switch off the power!!!*

## Meter wiring

### Evaluation unit

As a standard, the evaluation unit is in Ex ia design delivered for 10V (120mA) až 24V (55mA) supply voltage.

The flow meter signal outputs must only be connected to devices where accident protection is provided by safe low voltage and where generated voltages do not exceed the limits defined for safe low voltage.

The power supply of flowmeter and a meter outputs (pulses, 4-20 or 0,2-1mA) are connected to a connector, which is an integral part of the flowmeter and through which is connected to the desired devices. During any installation works must be flowmeter disconnected from the power supply.

### Standard wiring of connector on body of flowmeter

- 1 – power supply +
- 2 – power supply -
- 3 – output (pulses - emitor optocoupler – negative pole)
- 4 – output (pulses - colector optocoupler - positive pole)
- 5 – output (4-20mA or 0,2-1mA – negative pole)
- 6 – output (4-20mA or 0,2-1mA - positive pole)
- (7) – grounding

### Devices for group I (I M1 Ex ia I Ma)

Conecctor Amphenol C016



### Devices for groups II (II 1G Ex ia IIC T6 Ga a II 1D Ex ia IIC T85°C Da)

Connector SEALCON Signal Connector M23

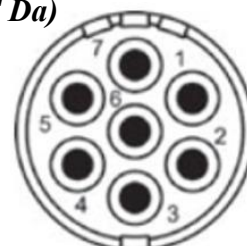

Insert Pin mating view

Recommended connecting cables:: *Lapp Kabel*  
Oelflex EB  
Oelflex EB CY  
Unitronic Li2YCY

Power supply characteristics FLOW 33 Ex ia

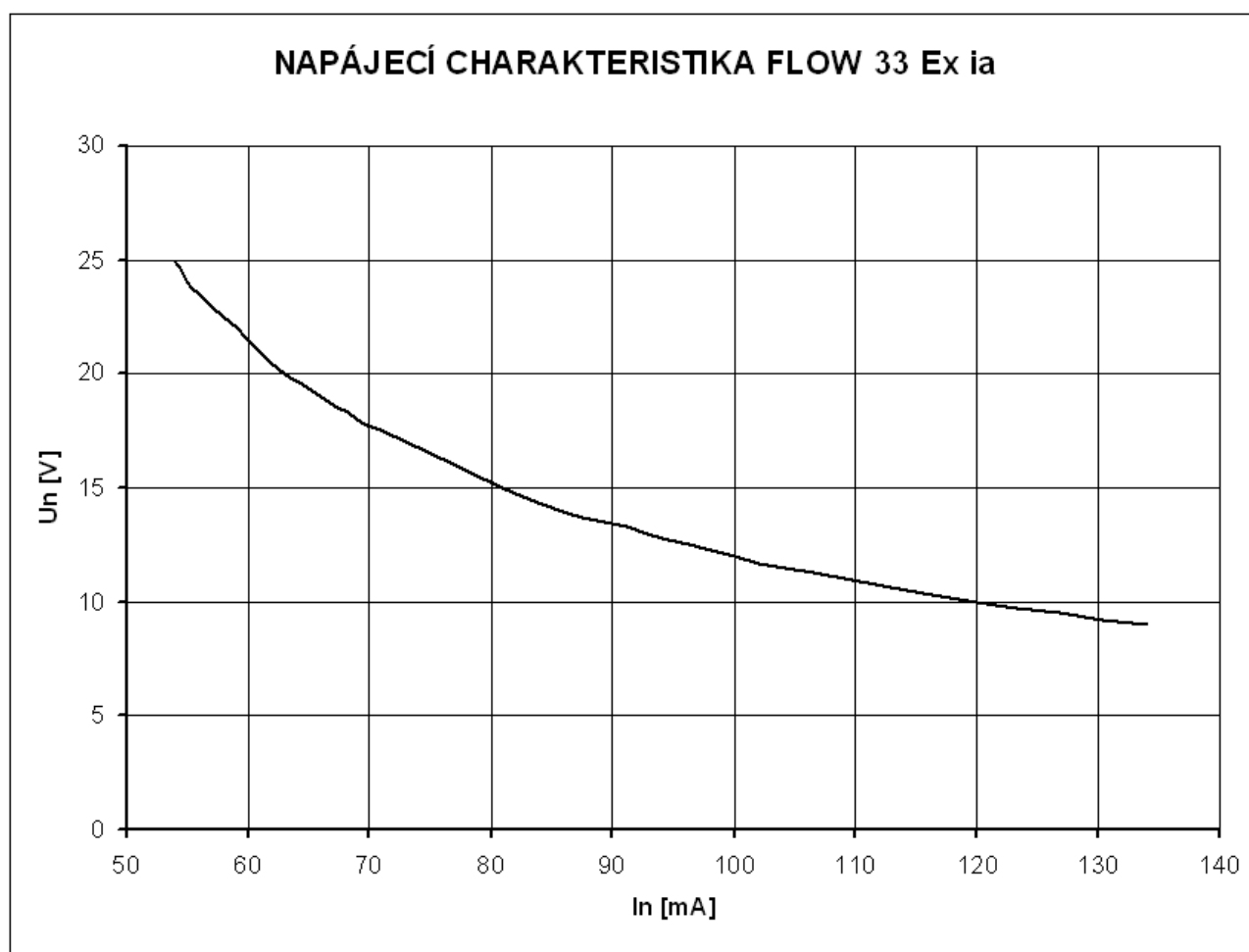

## Pulse Output

Pulse output is realized via optocoupler with switching transistor NPN. Limited parameters of this optocoupler are max.300V/150mA/100mW.

Pulse output is used for remote transfer volume of pulses and for the metrological verification of the flowmeter. When you order, can be constant freely adjusted (data type float), but later modification by the customer is not possible.

Optocoupler loading should be chosen so do not to exceed of the limited parameters:

Loading charakteristic ( $I_f = 2,5\text{mA}$ )

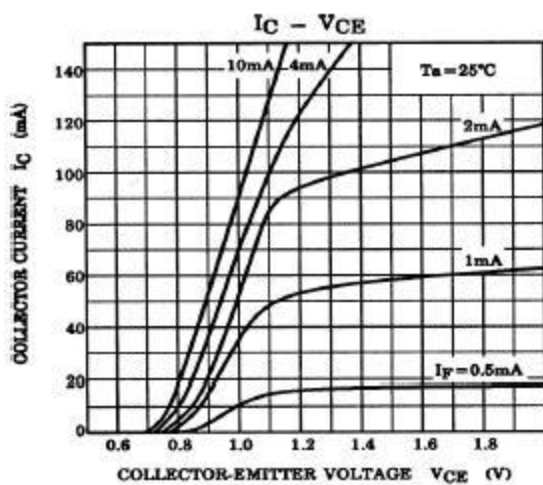

Wiring example

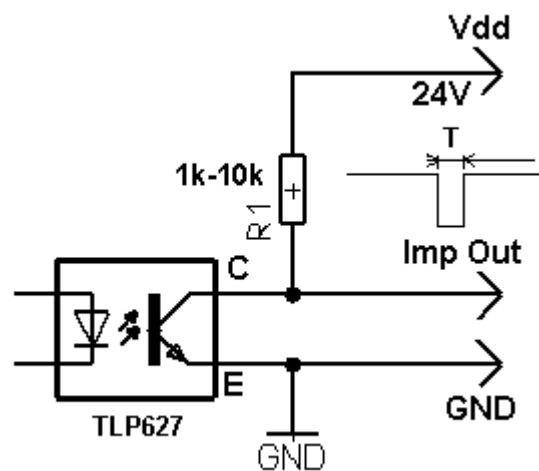

Maximal frequency of pulse output is 800Hz with puls width min. 250 $\mu\text{s}$ .



## 4-20mA output

4-20mA output could be in two versions:

Passive: 4mA až 20mA  
Active : 0,2mA až 1mA

### **4mA – 20mA:**

D/A – convertor of flowmeter FLOW33Exia is 16bit with updating dates each 80ms. Converter is galvanically isolated by optocouplers from the flowmeter. 4-20mA output is needed to powered from an external power. Voltage of external power  $U_e$  could be 12 až 24 V. Resistance of current loop must not be higher than  $R = U_e / 0,02$  ( $\Omega$ ;V).

### **0,2mA – 1mA:**

D/A – convertor of flowmeter FLOW33Exia is 16bit with updating dates each 80ms. **Converter is NOT galvanically isolated** from the flowmeter. Current loop is active and powered from flowmeter. Outputs voltage  $U_o$  is max. 25,2 V. Output resistance of current loop is 4700  $\Omega$ . The default setting is that at maximum flow  $Q_{max}$  is 20 mA(1mA) and at zero or negative flow 4 mA (0.2 mA). The current value is proportional to the value of the flow in the sample.  $Q_{max}$  (20mA nebo 1mA) is freely adjustable (float data type) when ordering the meter. In case of failure or power loss falls down the current loop output to 0mA and can be detected faulty status by superior system.

*Example of passive wiring of current loop:*

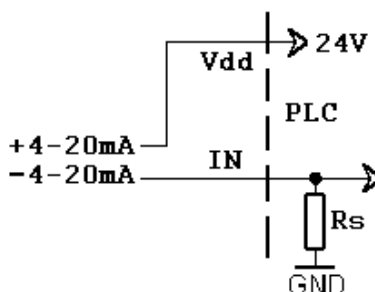

## Wiring check

After completion of wiring, it is necessary to check:

- Connecting cables for damage.
- Cables for pull relief.
- Correct connection of cables to terminals.
- Whether the supply voltage corresponds with the nameplate data.

## Putting into operation

Prior to connection to power supply, check the device installation accuracy in accordance with “Installation in pipeline” and “Wiring” chapters.

If the meter has no electrode for empty tube detection, do not connect the meter to power before filling the system with the fluid to be measured and power off the meter before system discharge.



It is important for ceramic measuring tube, while the piping is filled with a medium, to maintain gradual warming up or cooling down the ceramic measuring tube, always by 50°C at the most, and after 5 minutes every time. Failure to observe these conditions may result in destruction of the measuring tube.

*If you wish the meter to take measurement as precisely as possible right after powering up, it is a good idea to fill the flow sensor with water, one or two days before its installation, so that all of its electrodes are flooded. Just before the installation, the water is discharged and the sensor is installed into piping. Right after installation, piping is filled with a medium so that the electrodes cannot dry off.*

After the meter is powered up, the green LED on the top cover next to the connector is lit, confirming the supply voltage on the control PCB and stabilization of parameters of the meter takes place afterwards (approx. 20sec). After that period of time, the meter starts measuring.

### Meter status:

It is continuously displayed by two indicator LEDs located in the evaluation unit top cover (next to connector). The meter status indicated by the LEDs can be as follows:

LED1	LED2	Description	Current output
 green	-	The meter is in good order and the flow is null or negative	4mA
 green	 blue is flashing	The meter is in good order and the flow is positive where the blue LED is indicating the transmission of volumetric pulses	4÷20mA
-	-	Supply voltage error	-

### Flow direction:

*The arrow indicates the direction liquid flow inside the sensor and thus the correct orientation of the meter's sensor for installation in piping.*

### *Basic parameter settings*

The meter or flow meter parameters are set by the manufacturer in accordance with the purchase order. If these values are not indicated in your purchase order, the meter will be set up using the default parameters in accordance with the meter's range.

<b>Measuring range boundary values</b>	Refer to meter's nameplate
<b>Excitation time constant</b>	Standard 140 ms
<b>Impulse output width /gap</b>	Adjustable by producer (from 600 $\mu$ s)
<b>Impulse output constant</b>	fmax [800 Hz] => Qmax
<b>Flow at 4mA current output</b>	Meter minimum flow, refer to meter nameplate
<b>Flow at 20mA current output</b>	Meter maximum flow, refer to meter nameplate
<b>Current loop - meter error status</b>	<4mA
<b>Application</b>	Stable flow

### *Safety rules for operator*

Any interventions in the inductive flow sensor and evaluation unit itself are illegal on the part of operator and they may lead to direct scalding by medium. Perform electrical connection always after powering off.

For use in conditions where is occurrence of explosion of gases and dust and gassy coal mines apply the following safety parameters and standards.

## ***Technical data***

Power	10V/120mA ÷ 24V/55mA
Input power	1,2 ÷ 1,3 W
Electrical connection	Connector Amphenol C016 (I M1 Ex ia I Ma) Connector SEALCON Signal Connector M23 (II 1G Ex ia IIC T6 Ga a II 1D Ex ia IIIC T85°C Da)
Display	2× LED (meter status)
Construction	compact
Max. temperature of medium	40 °C
Size	DN 15÷200
Lining material	rubber (hard, soft, for potable water): DN20÷DN200 PTFE: DN 15÷DN 200
Electrode material	CrNi steel DIN 1.4571, Hastelloy C4, Titanium, Tantalum
Construction	all-welded frame
Sensor material	flanged – stainless steel and structural steel with polyurethane coating sandwich, threaded, food processing – stainless steel
Process connection	sandwich flanged DIN (EN1092) threaded (EN ISO 228-1) food processing (fittings DIN 11851, clamp)
Measure range (Qmin/Qmax)	unidirectional/bidirectional for 0.2÷12 m/s (1/60)
Flow meter accuracy	up to 0.5 % (for 0.1 ÷ 10m/s)
Repeatability	up to 0.2% (for 0.1 ÷ 10m/s)
Min. medium conductivity	20µS/cm (at a lower conductivity, upon agreement with manufacturer)
Outputs (passive)	impulse (max. 1.6 kHz, selectable constant) analogue 4÷20 mA or 0,2 ÷ 1 mA
Sampling:	800 samples per second (standard)
I/O response:	70ms (current loop)
Max. ambient temperature	55°C
Ambient humidity:	max. 90%
Pressure	PN10, PN16, PN25, PN40
Pressure loss	negligible
Flow sensor protection	IP65, IP67, IP68
Electronics protection	IP65

### **Negative pole of powering is connected with grounding of flowmeter via safety resistor**

Outputs signals of pulses and 4-20mA are passive and galvanically isolated from the electronics of flowmeter and from power supply of flowmeter.

Output signal of current loop 0,2–1mA is active and is galvanically connected with power supply of flowmeter.

If you do not find your size or structure in the Flow sensor technical parameters Table, it is a special or non-standard design. In this case, find the information on the sensor nameplate where this information is always indicated, or please contact the manufacturer for more detailed information.

*Error limits at reference conditions*

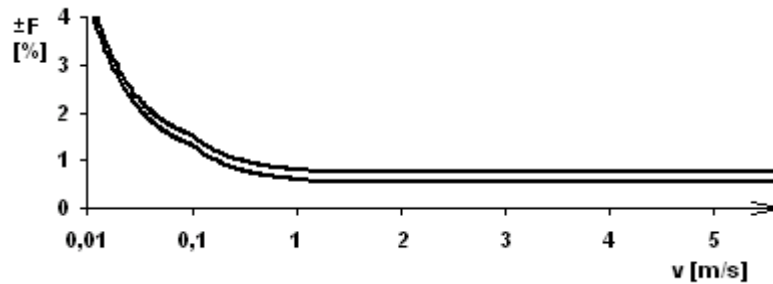

Diameter nominal	Measured value maximum error			Curve
	v ≥ 1 m/s	1 m/s > v ≥ 0,1 m/s	v < 0.1 m/s	
DN [mm]				
≤ DN 10	0.8 % of M*	0.72 % + 0.8 mm/s	1.17 % + 0.35 mm/s	1
≥ DN 15	0.6 % z M*	0.52 % + 0.8 mm/s	0.97 % + 0.35 mm/s	2

\* Of M – of the measured value

## *Safety information*

### **Selection according to the zones :**

**I M1 Ex ia I Ma** – mines with the risk of explosion of methane

**II 1G Ex ia IIC T6 Ga** – gassy atmosphere types hydrogen – zone 0 – permanent leak

**II 1D Ex ia IIC T85°C Da** – atmosphere with conductive dust zone 20 – permanent presence

### **For use in gassy coal mines, are valid following safety parameters and standards**

ČSN EN 50303 (June 2001); ČSN EN 60079-0 (March 2010); ČSN EN 60079-11 (June 2012)

### **For use in explosive gas atmosphere are valid the following safety parameters and standards**

ČSN EN 50303 (June 2001); ČSN EN 60079-0 (March 2010); ČSN EN 60079-11 (June 2012); ČSN EN 60079-26 (September 2007); ČSN EN 60079-10-1 (December 2009)

### **For use in flammable dust atmosphere are valid the following safety parameters and standards**

ČSN EN 50303 (June 2001); ČSN EN 60079-0 (March 2010); ČSN EN 60079-11 (June 2012); ČSN EN 60079-26 (September 2007); ČSN EN 60079-10-2 (February 2010)

### **Security classification :**

**I M1 Ex ia I Ma**

**II 1G Ex ia IIC T6 Ga**

**II 1D Ex ia IIC T85°C Da**

### ***Power supply:***

**U<sub>i</sub> : 28 V**

**P<sub>i</sub> : 4,832 W**

**C<sub>i</sub> : 0**

**L<sub>i</sub> : 0**

### ***Passive puls output***

**U<sub>i</sub> :** max. 13,6 V

**I<sub>i</sub> :** max. 20 mA

**P<sub>i</sub> :** max. 0,068 W

**C<sub>i</sub> :** zanedbatelné

**L<sub>i</sub> :** zanedbatelné

***Current loop 4 – 20 mA passive (standard)***

<b>U<sub>i</sub>:</b>	max. 28 V
<b>I<sub>i</sub>:</b>	max. 93 mA
<b>P<sub>i</sub>:</b>	max. 0,7 W
<b>C<sub>i</sub>:</b>	negligible
<b>L<sub>i</sub>:</b>	negligible

***Current loop 0,2 – 1 mA active (variante on request)***

**Devices of group I**

<b>U<sub>o</sub>:</b>	max. 25,2 V
<b>I<sub>o</sub>:</b>	max. 8,8 mA
<b>P<sub>o</sub>:</b>	max. 0,0552 W
<b>C<sub>o</sub>:</b>	< 2,2 μF
<b>L<sub>o</sub>:</b>	< 300 mH

**Devices of group IIC a IIIC**

<b>U<sub>o</sub>:</b>	max. 25,2 V
<b>I<sub>o</sub>:</b>	max. 8,8 mA
<b>P<sub>o</sub>:</b>	max. 0,0552 W
<b>C<sub>o</sub>:</b>	< 0,06 μF
<b>L<sub>o</sub>:</b>	< 1 mH

**!! WARNING !!**

**Due to the fact that active current loop 0,2-1mA is galvanically connected with electronics and power supply it is necessary that the power source of the flowmeter and the connected evaluation device had the same level of protection (EPL).**

**Inputs and outputs of devices connected to flowmeter must be equipped with protection"ia".**

Powering protection: SMD speed fuse SIBA type 157000 160mA

Outputs protection : SMD speed fuse SIBA type157000 62mA

## *Factory settings*

The impulse output is always selected as the nearest decimal constant, satisfying the condition that the output frequency at the maximum flow for the given DN size is not higher than 800 Hz. The current loop is set in such a manner that 4 mA corresponds to zero flow and 20 mA corresponds to its maximum value.

### *Impulse constants and current loop – factory settings*

<b>Diameter nominal DN</b>	<b>Impulse output</b>		<b>4 – 20mA (in Qmin/Qmax 1/100 range)</b>	
	Vout[imp/l]	Vout - pulse width [ms]	Q[l/h] for 4mA	Q[l/h] for 20mA
15	10	4	0	7,600
20	10	4	0	14,200
25	10	4	0	21,000
32	1	4	0	34,000
40	1	4	0	54,000
50	1	4	0	84,000
65	1	4	0	144,000
80	1	4	0	220,000
100	0.1	4	0	340,000
125	0.1	4	0	534,000
150	0.1	4	0	760,000
200	0.1	4	0	1,350,000

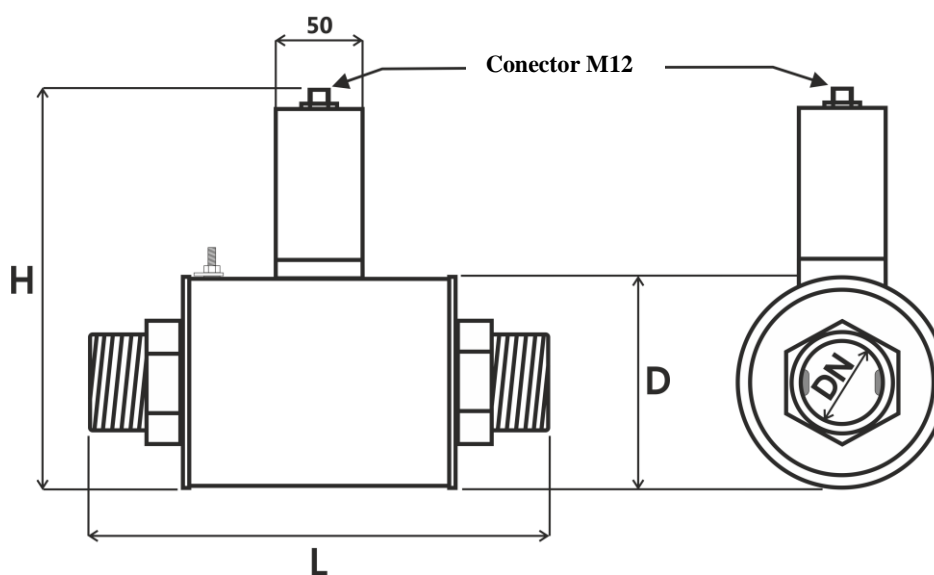

*Table with flow ranges for individual DN sizes*

Diameter nominal [mm]	Qmin [m3/h] as per Qmin /Qmax		Qmax [m3/h] (12 m/s)
	1/60 (0.2 m/s)	1/100 (0.12 m/s)	
DN 15	0.13	0.076	7.6
DN 20	0.24	0.142	14.2
DN 25	0.35	0.21	21
DN 32	0.6	0.34	34
DN 40	0.9	0.54	54
DN 50	1.4	0.84	84
DN 65	2.4	1.44	144
DN 80	3.6	2.2	220
DN 100	5.6	3.4	340
DN 125	8.9	5.34	534
DN 150	13	7.6	760
DN 200	23	13.5	1350

## *Basic sensor sizes*

### *Threaded design*



Diameter nominal [mm]	Threaded connection	D External $\varnothing$ sensors	L Building length of sensor	H Building height of comp. meter	Compact flow meter weight (kg)
15	1/2"	69	196	188	4
20	3/4"	79	206	194	4
25	1"	89	206	204	5
32	1 1/4"	99	233	210	5
40	1 1/2"	115	256	232	6

*The Table is for PN25.*

*Inter-flanged design*

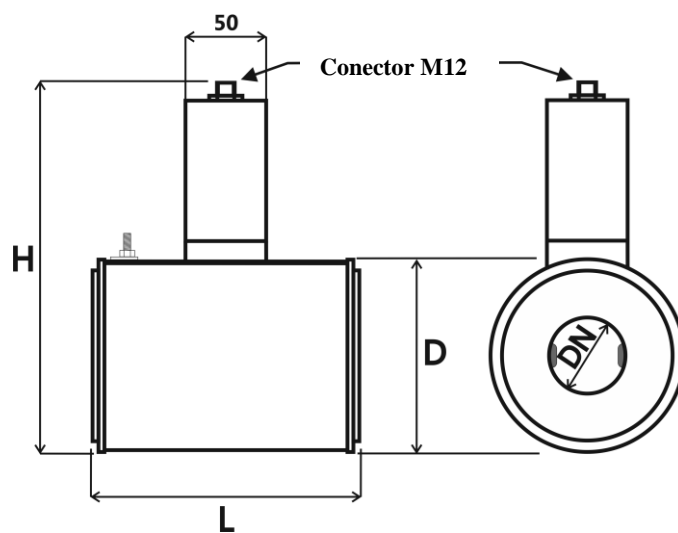

Diameter nominal [mm]	D Outside diameter of sensor	L Building length of sensor	H Building height of comp. meter	Compact flow meter weight (kg)
15	51	90	188	2
20	61	90	198	2
25	71	90	208	3
32	82	90	219	3
40	92	110	229	4
50	107	110	244	4
65	127	130	264	5
80	142	130	279	6
100	168	200	305	7
125	194	200	331	9
150	224	200	361	11
200	284	200	420	14

*The Table is for PN25.*

*Flanged design*

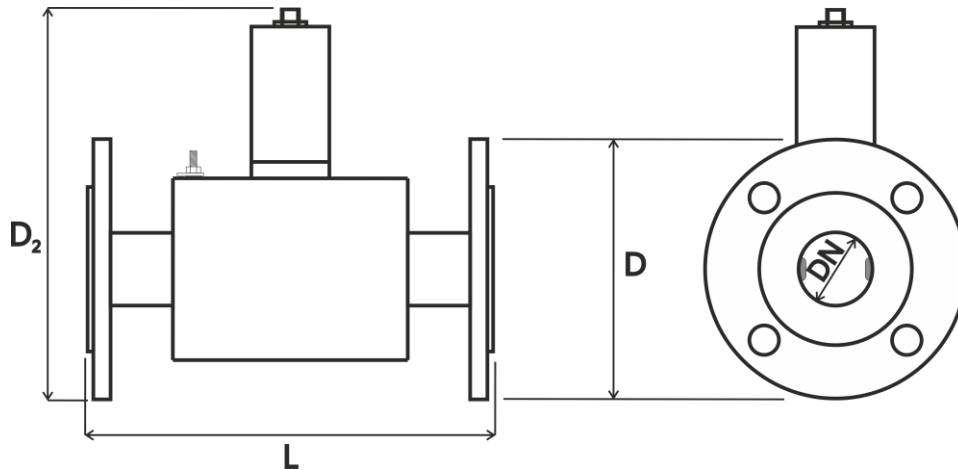

Diameter nominal [mm]	D Outside diameter of flanges	L Building length of sensor	H Building height of comp. meter	Compact flow meter weight (kg)
15	100	200	223	4
20	110	200	233	4
25	120	200	243	5
32	140	200	258	6
40	150	200	268	7
50	165	200	293	9
65	185	200	313	11
80	200	200	328	12
100	220	250	353	19
125	250	250	383	26
150	285	300	413	37
200	340	350	473	44

*The Table is up to DN 200 for PN25.*

Food industry design

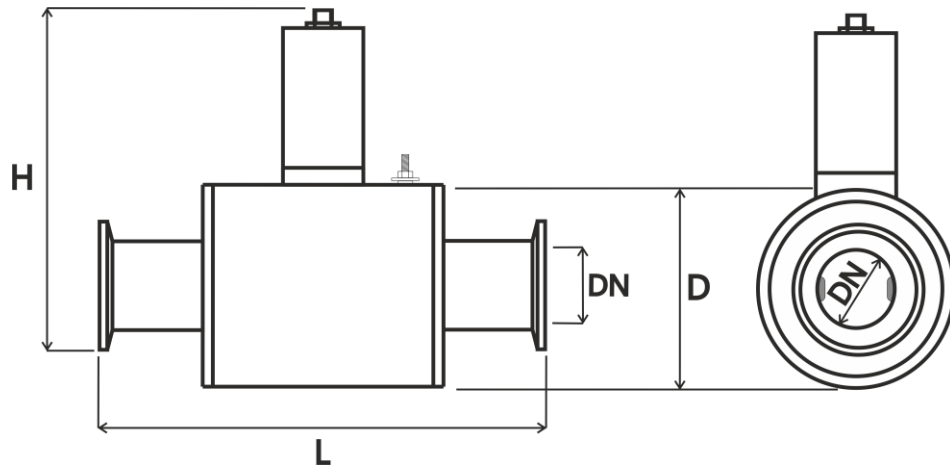

Diameter nominal [mm]	Food grade connection CLAMP/ Screwed fitting	D External Ø sensors	L Building length of CLAMP	L Building length of food grade screwed fitting DIN11851	H Building height of comp. meter	Compact flow meter weight (kg)
15	DN 15	69	182	172	188	4
20	DN 20	79	182	176	194	4
25	DN 25	89	182	186	204	5
32	DN 32	99	189	197	210	5
40	DN 40	115	210	220	232	6
50	DN 50	135	217	231	236	7

The Table is for PN25.

Diameter nominal [mm]	DN 15 ÷ DN 20	DN 25 ÷ DN 40	DN 50	DN 65	DN 80
Outside dimension of CLAMP [mm]	34	50,5	64	91	106

## *Nomogram for quick proposal of the measured place*

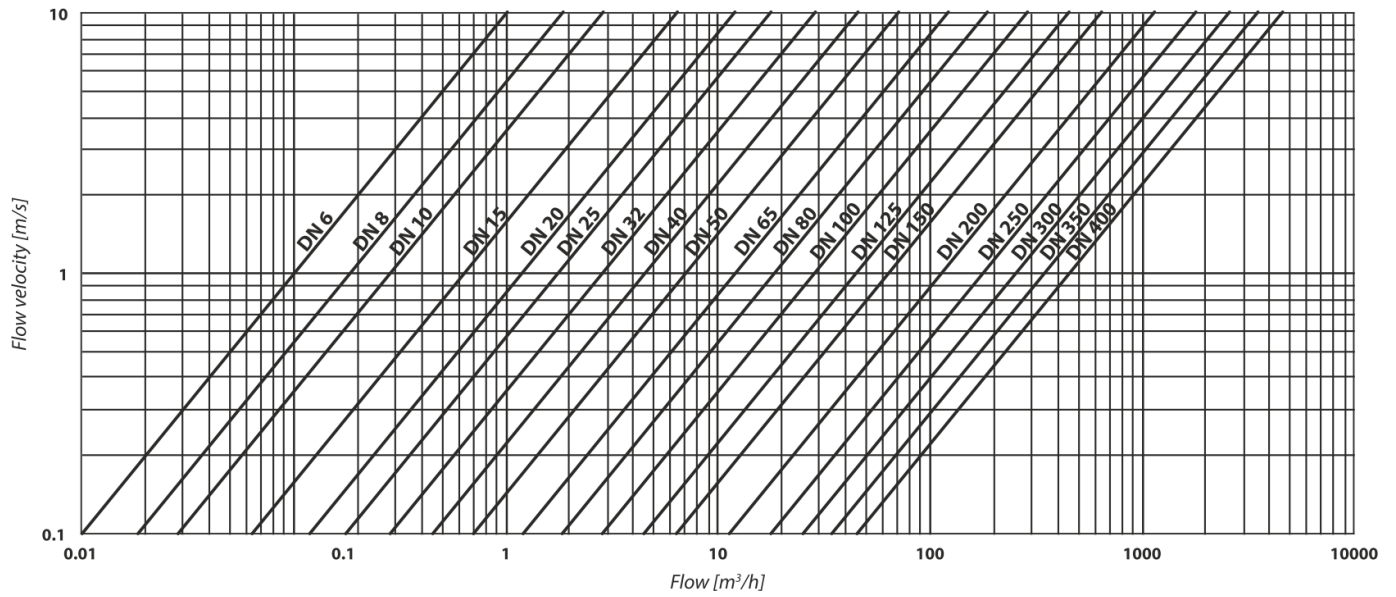

## *Reduction in DN pipe*

*If the pipe's DN is higher than that of the meter selected*

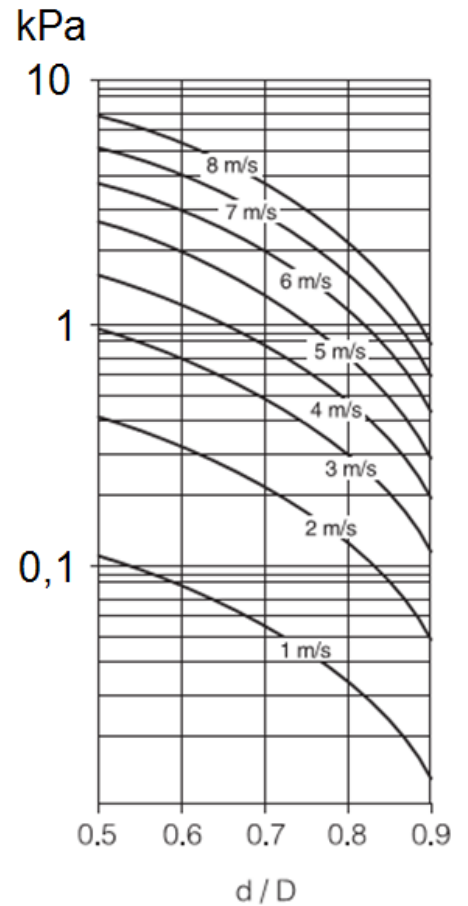
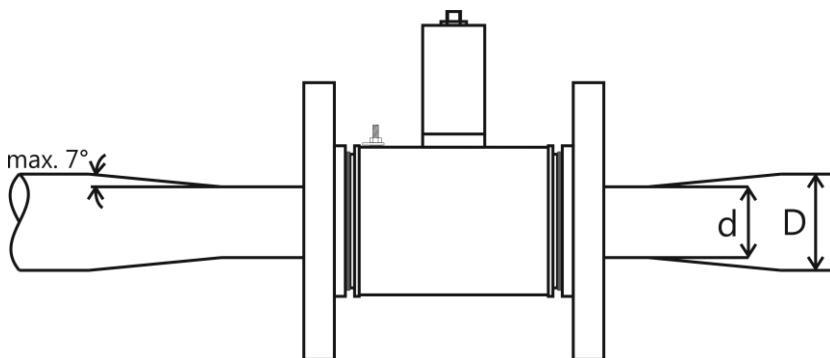

## ***Failures and their symptoms during measurement***

Unstable indications and readouts may appear due to:

- big portion of solids
- in homogeneities as a result of the state of matter
- turning point of immixture
- continuous chemical reactions in the measured fluid
- use of diaphragm pumps or plunger pumps
- poor grounding

## ***Flow sensor cleaning***

Some measured liquids contain substances and chemicals that tend to form layers inside the pipes including the measuring pipe, which may affect the measurement accuracy. In this case it is necessary to clean the flow sensor from time to time. Ceramic pipes can be cleaned mechanically with a steel brush and then the cleaning can be completed using diluted hydrochloride acid or citric acid solution. The acid removes calcareous layers or black layers of iron complex. If the contamination is greasy, it must be cleaned by caustic soda or potassium hydroxide solution. Flow sensors with teflon, plastic and rubber measuring pipe cannot be cleaned mechanically with a brush, it is only possible to clean them chemically. After cleaning, the pipe must be properly rinsed with water.

## ***Service***

All repairs within warranty and after warranty period are only conducted by the manufacturer, **COMAC CAL s. r.o.**

## Order code

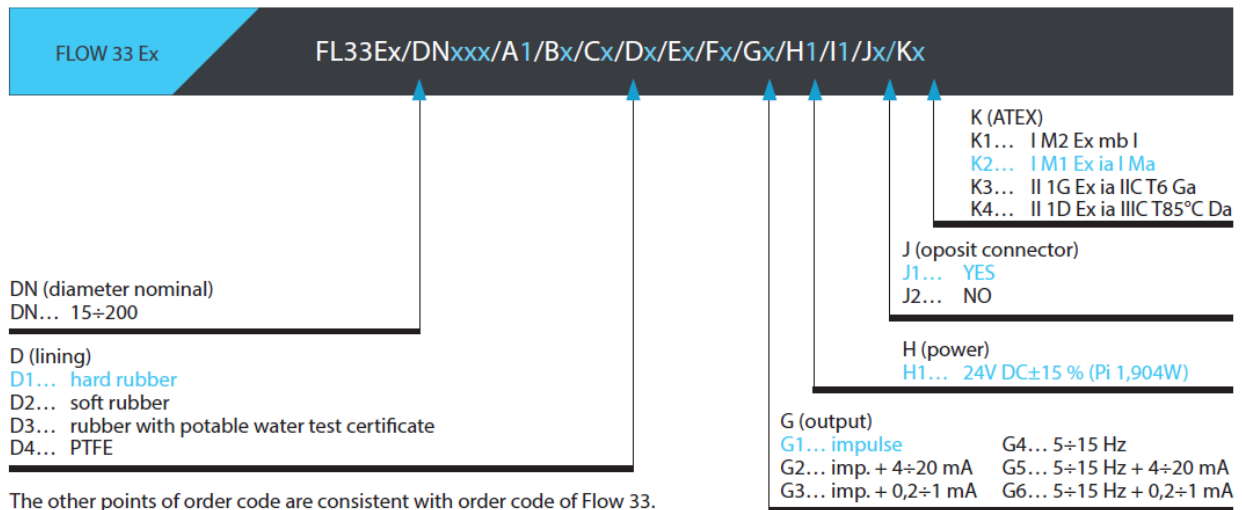
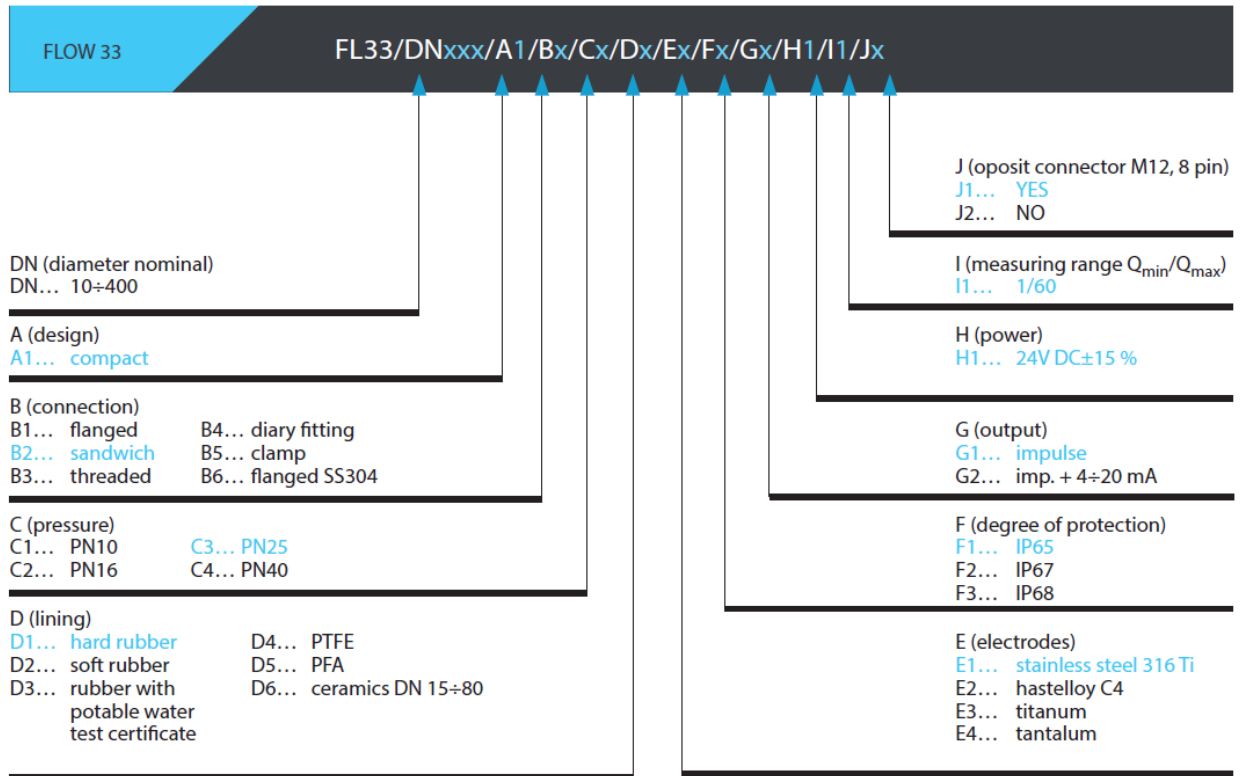

The other points of order code are consistent with order code of Flow 33.  
Standard set include installation manual and calibration certificate.  
For other requirements, please contact the manufacturer directly.



***Form for returning the meter to COMAC CAL s.r.o.***

The meter you have was made with the maximum precision and it has been checked many times and wet calibrated.

If the meter is used in agreement with this manual, the occurrence of faults is very rare. Should they ever occur, contact our service department. If you return the meter to the manufacturing plant, adhere to the conditions stated below:

- Clear the meter of contaminations stuck to the sensor and measuring tube (eventually to the Evaluation Unit).
- If the meter was run with poisonous, etching, combustible liquids or with fluids dangerous to water, check it and if appropriate, flush and neutralize the cavities inside the sensor.

Fill in the following data please and the form duly completed attach to your consignment. COMAC CAL s.r.o. will not be able to process your request promptly and correctly without this form.

---

*Customer*

Company..... City.....  
Department..... Name.....  
Phone no.....

*Enclosed meter*

Type..... Serial number.....  
Measured liquid.....

Description of a fault or modifications required.....  
.....  
.....  
.....

We confirm that the meter was duly cleaned, and if required, it was flushed out and neutralized. Therefore, this consignment does not constitute any risk to humans and environment due to remnants of the measured fluid.

Date..... Signature and stamp.....