

DEW POINT SENSOR (-20 ... +50 °C Td) S215



COMPACT DESIGN
Makes it easy to fit into the application



Ensure your dry air — monitor the dew point



S215 FEATURES



COMPACT DESIGN
Makes it easy to fit into the application



PRECISE MEASUREMENT
Long term stable results



DEW POINT
Measures down to -20 °C Td



ANALOG OUTPUT
4..20 mA loop powered

The SUTO dew point sensor S215 provides reliable and long term stable dew point monitoring in industrial applications. With this model dew point measurement in refrigerant dryers becomes affordable and can replace traditional temperature measurement which often couldn't tell the real dew point.

S215 outputs the measurement value through the loop powered 4-20 mA signal.

S215 DIMENSIONS

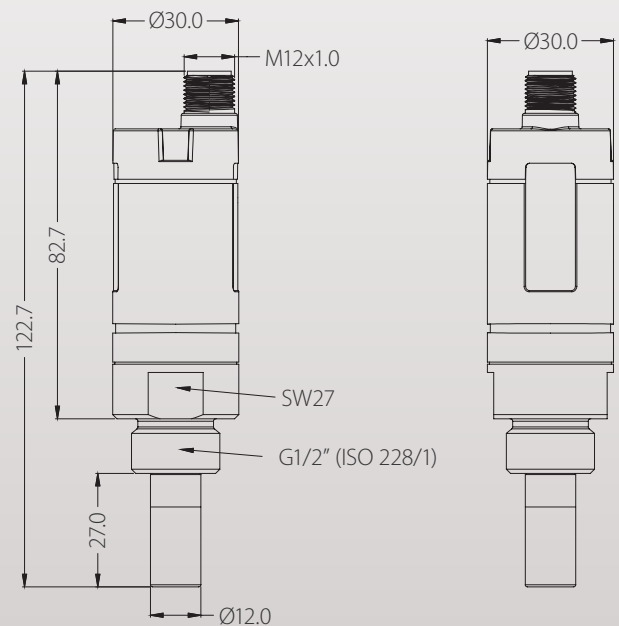
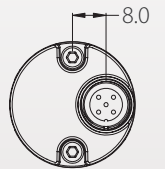

S215 BENEFITS

- Affordable dew point sensor for mid range applications such as refrigerant dryer monitoring
- Long term stability
- IP65 casing provides robust protection in rough industrial environment
- Fast response time ensures safe and reliable indication whenever dew points are out of valid ranges
- Can be installed directly into dryers through G 1/2" thread
- High accuracy of ± 2 °C dew point

S215 TECHNICAL DATA

General Specifications	
Measuring range	Dew point -20 ... +50 °C Td Temperature -30 ... +70 °C
Dew point sensor	Polymer
Temperature sensor	NTC
Pressure sensor	N/A
Accuracy	Dew point ± 2 °C Td Temperature 0.3 °C
Operating Pressure	-0.1 ... 5.0 MPa
Operating Temperature (Medium)	-30 ... +70 °C
Measured gases (Medium)	Air, Argon, O ₂ , N ₂ , CO ₂
Response Time t90 (@ 4 l/min)	-20 °C Td -> +20 °C Td = 20 sec +10 °C Td -> -20 °C Td = 60 sec
Ambient Temperature	-20 ... +50 °C
Ambient Humidity	0 ... 100 % rH
Supply Voltage	12 ... 30 VDC
Current consumption	20 mA @ 24 VDC
Output signals	4 ... 20 mA 2-Wire
Electrical connection	M12, 5 poles
Process connection	G 1/2" thread (ISO 228/1) Stainless steel 1.4301 (SUS 304)
Casing material	Zinc alloy
Classification	IP65
EMC	IEC 61326-1
Approval	-
Sensor protection	Sinter filter
Transport Temperature	-30 ... +70 °C
Storage Temperature	-20 ... +50 °C
Weight	195 g



Dew point sensor ideal for refrigerant dryers. Loop powered 4 ... 20 mA output.

S215 ORDERING

Please use the following table to assist in placing your order with our sales staff.



Visit our website or e-mail us:
www.suto-itec.com
sales@suto-itec.com

S215 DEW POINT SENSOR (-20 ... +50 °C Td)	
Order No.	Description
S699 0415	S215, dew point sensor including M12 connector (straight type), -20 ... +50 °C Td, G 1/2" thread
A699 4003	High pressure option 35 MPa (350 bar)